

Flameproof Alternator

Models ASX-200, ASX 201
ASX-300, ASX 301

Application

- For use in hazardous areas classified as Zone 1, Group IIB, T4
- Suitable for local ambient temperature range -30°C to +50°C
- Designed as a belt driven diesel engine mounted alternator

Key benefits

- Compact high performance design
- Certified for all international hazardous zones 1 or 2
- T4 rating gives safe performance in T3 areas
- Speed signal output for overspeed shutdown
- Certified cable gland included
- Wide choice optional pulleys
- Group 1 mining version available
- Suitable for offshore conditions

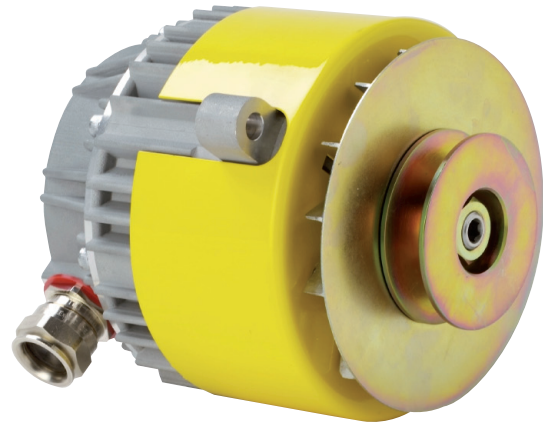

**Model ASX-200
Flameproof Alternator**

CHALWYN
by AMOT

Flameproof Alternator - Models ASX 200 - 300

Flameproof Alternator - Models ASX 200 - 300

Description

Twelve pole rotating field coil type externally excited alternators designed and approved as Category 2G/D equipment.

ASX200 and ASX300 ranges of alternators are marked as follows:

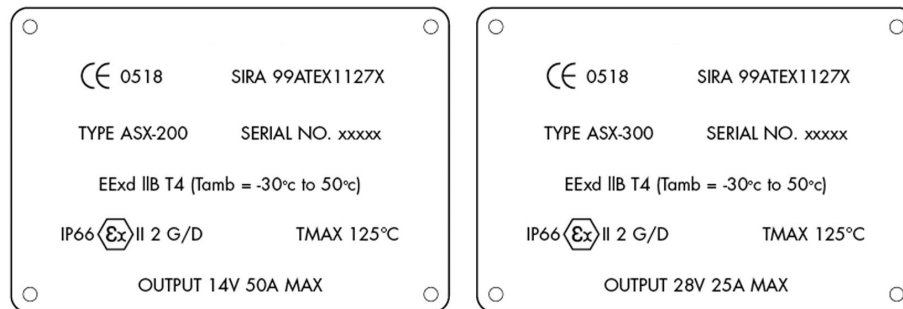

ASX alternators also meet the Electromagnetic Compatibility (EMC) requirements of MIL Std 461E Clauses RE102 and RS 103.

The outer enclosure of these alternators is manufactured from LM25 castings. Fan, fan discs, cowls and pulleys are manufactured from carbon steel. Overall dimensions are as given below. Note, side or rear cable entry options are available.

Diagram 2

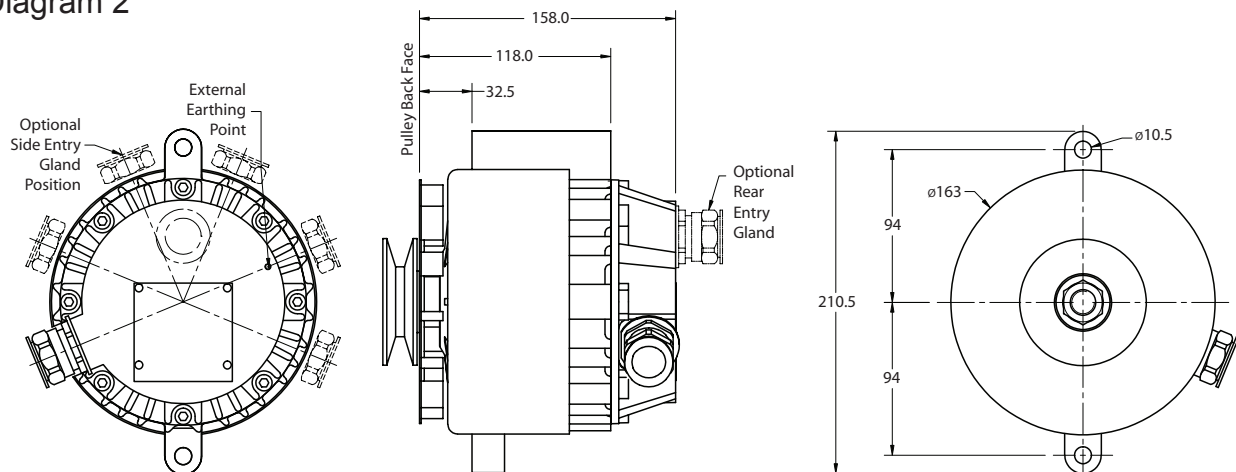

Notes:

To maintain full compliance with hazardous area and EMC requirements ensure:

- The external earthing point of the alternator and any armoured/screened cable are properly bonded to the engine/engine frame.
- Any connected electrical equipment is engineered to the requisite standard.

Flameproof Alternator - Models ASX 200 - 300

Application

Designed for application as a belt driven diesel engine mounted alternator for use in Zone 1, Group IIB, T4 applications. Suitable for a local ambient temperature range between -30°C and +50°C. Speed signal output available. Power output suitable for changing a medium sized diesel engine start battery, subject to the following limitation:

- The output demand not to exceed 50 amps for the ASX-200
- The output demand not to exceed 25 amps for the ASX-300

This equipment must not be used for other applications without prior approval of Chalwyn.

Selection

a. Either “side” or “rear” cable entry positions are possible for this product range but the requirement must be specified at the time of ordering. If the side entry option is selected, the rear cover of the alternator may be rotated to give various positions - see diagram page 2. Rear entry versions are designated as models ASX-201 and ASX-301.

Pulley Selection

Note the belt section size and select the appropriate width pulley from the table below. Take into account alternator speed range (see “Installation” paragraph 2) when selecting the most suitable diameter of a pulley. For latest details of the range of suitable pulleys please contact your Chalwyn distributor. Note, if a non Chalwyn pulley is to be fitted please forward design details to your Chalwyn distributor for approvals. When fitting a pulley use a 8mm hexagonal Allen drive in the rotor hole and tighten the nut supplied to 60 NM (44 lb feet) torque.

General Form	Belt Width	Drive Diameter (mm)	Pulley
SPA (Small)	1/2" / 13mm	55	ASX-546
SPA (Medium)	1/2" / 13mm	71	ASX-549
SPA (Large)	1/2" / 13mm	80	ASX-574
SPB (Small)	5/8" / 16mm	66	ASX-539
SPB (Medium)	5/8" / 16mm	71	ASX-548
SPB (Large)	5/8" / 16mm	90	ASX-563
6 Groove Poly-V	DIN 6-PK	56	ASX-575
6 Groove Poly-V	DIN 6-PK	66	ASX-556

Speed calculation formula

$$\frac{\text{Crankshaft pulley diameter (mm)}}{\text{Chalwyn pulley drive diameter}} \times \text{Engine Speed} = \text{Alternator Speed}$$

Flameproof Alternator - Models ASX 200 - 300

Installation

1. Remove any existing non-flame proof alternator from the diesel engine.
2. Check the alternator drive pulley ratio. In the case of fixed speed applications the pulley drive should be arranged to give a continuous alternator speed of between 5,000 rpm and 7,000 rpm. In the case of variable speed applications the pulley ratio should be selected to give an alternator speed of 2,000 to 2,500 rpm at the engine low idle. This typically equates to a normal operating alternator speed range of about 3,500 rpm to 8,000 rpm.

NOTE:

- a. The rear cover of the alternator may be rotated to give alternative cable entry positions.
 - b. The standard cable entry gland supplied with the alternator is suitable for sealing on the outer sheath of unarmoured cable or on the inner sheath of armoured cable within the size range of 12 to 20.5 mm diameter.
 - c. The recommended inner core sizes for ASX-310 are 4 mm². If suitable metric standard cable is not easily available and SWG or AWG must be used, please contact the Chalwyn factory with application details for technical advice on alternative possible cable core sizes.
 - d. After installing the cable, a cable clamping device should be applied as near as possible to the cable gland.
3. Prepare to fit the Chalwyn alternator in place of the standard alternator by modifying the support bracket and belt tensioning link as necessary. Check that adequate belt adjustment is available. Ensure that with the selected cable entry position, the alternator cable can be routed away from the alternator in such a way as to avoid potential mechanical or heat damage.
 4. Remove rear cover of alternator. Prepare correctly rated cable for fitting to the terminals as shown below. Note, the main positive and negative terminals and the ignition (excitation) positive terminal are designed for M5 ring connections. When slackening or tightening the "Nyloc" terminal nuts, particular care should be taken not to slacken the M5 nuts at the base of the terminal posts. Check these are tight after removing the "Nyloc" nuts. When tightening the Nyloc nuts prevent the terminal posts from rotating by holding with an open end spanner. The speed signal connection should be made

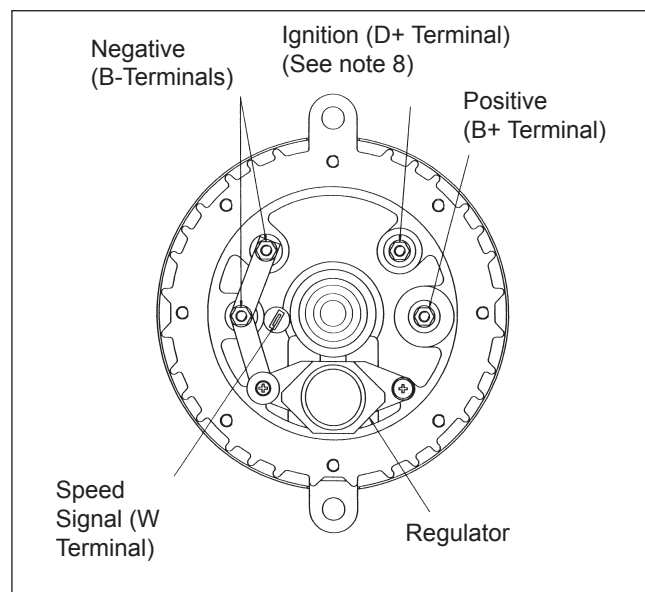

using a right angle spade connector to avoid bending the cable (eg RS part 161-2008). Use ties to restrain the cables to prevent mechanical damage.

5. Refit the rear cover after ensuring the "O" ring seal is undamaged and is properly seated in the seal groove. Torque the rear cover fasteners to 15 Nm (11 lb feet).
6. Fit alternator to engine. See diagram on page 2 for location of earth / ground threaded hole. Fit external earth wire from M4 tapped hole in the alternator rear cover to a clean position on the engine. Use a 4mm² section cable, ring terminals and shake proof washers. Also check that the engine is electrically bonded to its base frame or equivalent and, if metal braided armoured cable is used, the braiding is electrically bonded to the engine.
7. Fit an antistatic (conductive) drive belt and check it is correctly tensioned. The maximum side force must not exceed 565 Newtons (127 lbs) to avoid premature wear and alternator failure. Any sprung tensioner as used in serpentine drive arrangements must be adjusted so that the side force limit is not exceeded.
8. The ignition/excitation cable to the Chalwyn alternator D+ terminal must be connected to the battery positive via an ignition switch and a warning lamp as in an automotive style arrangement. This warning lamp to illuminate to indicate:
 - a. Engine not running. Ignition (excitation) circuit powered.
 - b. Engine running. Alternator output low (battery discharging).

Flameproof Alternator - Models ASX 200 - 300

Special Notes

a. The cable entry point exceeds 70°C under rated conditions, therefore, in accordance with EN50014:1997 clause 16.8, suitably rated cable shall be selected for installation.

b. The output voltage from the alternator is controlled by an internal regulator. It is recommended however that “over voltage” protection is fitted to any circuit supplied by the alternator in which one or more components could become a potential source of ignition should “over voltage” occur.

Operation

Operate engine as per a normal diesel engine. ie turn ignition on (ignition warning lamp should illuminate). Crank engine and run up to speed (warning lamp should cease to be illuminated). Should ignition warning light illuminate at any time that the engine is running within its normal speed range, the engine must immediately shut down for alternator, battery and electrical system checks to determine the reasons for the problem. The engine must not be operated again in a hazardous area until the problem has been identified and rectified.

Maintenance

Routine maintenance is to be undertaken as follows:

Monthly

- Check drive belt is in serviceable condition and is correctly tensioned.
- Check alternator mounting fasteners are tight.
- Check alternator cable is properly supported and free from damage.
- Check air passages under fan cowl are clear of any significant build up of foreign matter.
- Check to ensure good electrical bonding exists between the alternator, engine and engine base frame and, if applicable, the metal braiding of the alternator output armoured cable.

Three Monthly

- Check end float at alternator cooling fan. This must not exceed 0.2mm when alternator is cold.
- Check fan to cowl clearance. At worst point this must be greater than 1.0mm

Yearly (or each 2,000 hours whichever occurs sooner)

- Remove alternator rear cover. Loosen the two fasteners locating the regulator carefully noting the position of the insulating and steel washers (see diagram under INSTALLATION). Replace regulator brush assembly with a new assembly ensuring the various washers are replaced correctly and the fasteners are re-tightened.
- Check and tighten as necessary all terminals.
- Check in turn that each alternator terminal is electrically isolated from the alternator body.
- Check rear cover “O” ring seal is suitable for further service and is properly located in the seal groove. Refit rear cover torqueing fasteners to 15 Nm. Tighten cable gland.
- Clear any dust from the rear cover area. Check cable condition is acceptable for further service.

Maintenance Note:

- The M6 socket head cap screws utilised for fastening the end covers must only be replaced by cap screws with a yield strength better or equal to 830 N/mm² in accordance with EN 50018:1994, clause 11.3
- Any maintenance problems not covered by the above routine maintenance schedule should be discussed with your Chalwyn distributor before any repair work is undertaken.

Flameproof Alternator - Models ASX 200 - 300



Chalwyn by AMOT

sales@chalwyn.co.uk
www.chalwyn.com

A division of Roper Industries Limited

UK

Western Way
Bury St Edmunds
Suffolk, IP33 3SZ
Tel: +44 (0)1284 715739
Fax: +44 (0)1284 715747

USA

8824 Fallbrook Drive
Houston
TX 77064
Tel: +1 281 940 1800
Fax: +1 713 559 9419

Canada

3230 97 Street
Edmonton
Alberta, T6N 1K4
Tel: +1 780 465 4429
Fax: +1 780 469 6275

Asia

AMOT Shanghai
Rm A308 Building A8
Jiahua Business Center
808 Hongqiao Road
Shanghai 200030
China
Tel: +86 (0) 21 6447 9708
Fax: +86 (0) 21 6447 9718

