

CHALWYN

DIESEL PROTECTION SYSTEMS

**MVX-Series Diesel Engine Shut Down Valves
(Integral Manual Closure and Reset Lever Types)**

SELECTION, APPLICATION AND MAINTENANCE

Valve Numbers
MVX-300 MVX-500
MVX-800

DESCRIPTION

A range of mechanically actuated diesel engine air intake closure valves based on standard Chalwyn slimfit 3", 5" and 8" butterfly valves. Suitable for both hazardous and non-hazardous area applications where valve mounted manual trip and reset controls are required. Available in basic flange mounted form or fitted with hose adaptors or an integral flame trap housing. Body and disc manufactured in corrosion resistant hard anodised aluminium with PTFE coating. Spindle and mechanism made from 316 stainless steel.

Typical valve Arrangement

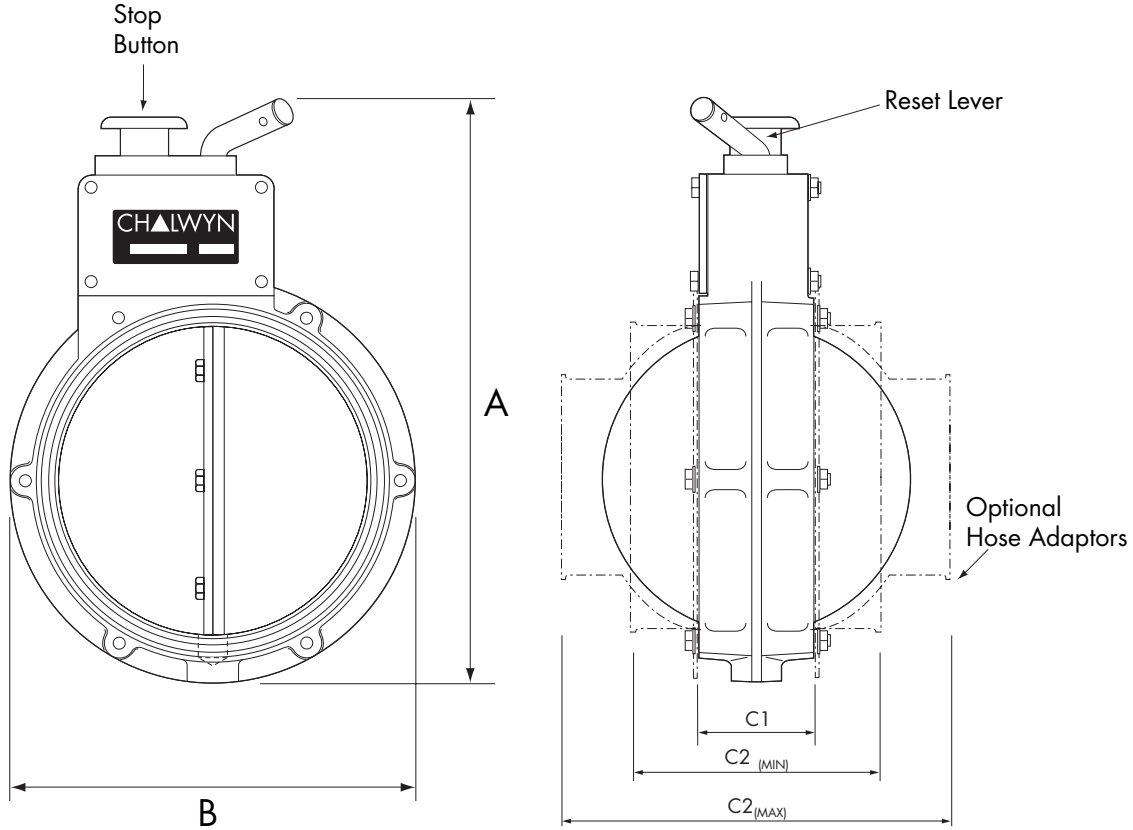

Main Dimensions (mm)

Valve Type	Nominal Bore Diameter	A	B	C ₁	C ₂ minimum & maximum
MXV-300	76 (3")	190.0	111.5	37.5	82.5 to 112.5
MXV-500	127 (5")	246.0	167.0	45.5	102.0 to 157.5
MXV-800	203 (8")	396.5	257.0	56.0	136.5 to 185.5

Notes:-

Maximum temperature of the engine intake air at the MXV valve not to exceed 150°C. (See also "Installation" - page 4).

For manually operated valves with remote stop button please see Chalwyn publication C217.

SELECTION

Determine the size and position of the MVX valve to be installed. Within the various constraints imposed in the application the valve should be as generously sized as possible.

Select an alternative valve type from the MVX, PVX or SVX range if the following circumstances apply:

- It is not possible to fit the valve in a position where the local manual controls are easily and safely accessible.
- The engine intake pipe layout dictates that more than one shut down valve is required.

Ideally if hose adaptors or an integral intake flame trap housing is to be used, these should be identified and ordered from Chalwyn at the same time as the basic MVX valve.

Hose Adaptor Options

76mm (3") Bore Valves	
Adaptor Part Number	To Suit Hose Bore mm (inches)
HAX-320	38 (1½)
HAX-322	44.5 (1¾)
HAX-301	51 (2)
HAX-302	54 (2 1/8)
HAX-303	57 (2 1/4)
HAX-304	60 (2 3/8)
HAX-305	63.5 (2 1/2)
HAX-306	67 (2 5/8)
HAX-307	70 (2 3/4)
HAX-308	73 (2 7/8)
HAX-309	76 (3)
HAX-312	82.5 (3¼)
HAX-314	89 (3 1/2)
HAX-319	102 (4)

127mm (5") Bore Valves	
Adaptor Part Number	To Suit Hose Bore mm (inches)
HAX-501	89 (3 1/2)
HAX-502	92 (3 5/8)
HAX-503	95 (3 3/4)
HAX-504	98 (3 7/8)
HAX-505	102 (4)
HAX-506	105 (4 1/8)
HAX-507	108 (4 1/4)
HAX-508	111 (4 3/8)
HAX-509	114 (4 1/2)
HAX-510	117.5 (4 5/8)
HAX-511	121 (4 3/4)
HAX-512	124 (4 7/8)
HAX-513	127 (5)
HAX-518	140 (5 1/2)
HAX-523	152 (6)

203mm (8") Bore Valves	
Adaptor Part Number	To Suit Hose Bore mm (inches)
HAX-807	178 (7)
HAX-808	203 (8)

INSTALLATION

1. In the case of a naturally aspirated engine, the Chalwyn MVX shut down valve should generally be fitted as close to the engine air intake manifold as possible. If an intake flame trap is also fitted, the MVX valve must be installed upstream (air cleaner side) of the flame trap.
2. To avoid excessively high intake air temperatures at the MVX valve when fitted to a turbocharged engine, it may be necessary to fit the valve either upstream of the turbocharger or downstream of the intercooler (if fitted). Again, if an air intake flametrap is also fitted, the valve must be installed upstream of the flametrap.
3. The valve may be installed either horizontally or vertically.
4. If hose adaptors are used, the mating hose should be of a reinforced type, provide adequate support for the valve and prevent excessive vibration. If necessary, additional support brackets mounted from the engine should be considered.
5. Particular care must be taken to ensure the integrity of the intake pipework between the Chalwyn valve and intake manifold. Ideally metal pipework should be used and any gaps kept as short as possible, (taking into account any relative movement) and closed by reinforced hose.
6. Any engine crankcase breather connections into the intake system between the MVX valve and engine, or any internal crankcase breather arrangement venting directly into the engine intake ports must be sealed and replaced by an external breather system venting either to atmosphere or to the intake system upstream of the shut down valve. External breather system kits for various engine types are available from Chalwyn.

OPERATION

Prior to starting the diesel engine, the MVX valve must be latched open by rotating the reset lever clockwise as far as possible. Once latched, the reset lever will remain in the latched open position until manually released by the stop button.

To carry out an emergency closure of the MVX intake valve to stop the engine, either press or pull the stop button on the valve. No attempt should be made to restart the engine until the MVX valve is again latched open.

MAINTENANCE

MONTHLY:

Check that the fasteners locating the MVX valve and any associated intake system or support bracket fasteners are securely tightened.

Check that any flexible hoses between the MVX valve and engine are free from damage and suitable for further service.

Run engine, preferably at low idle. Press MVX valve stop button. The engine should stop within a few seconds. If not check intake system between MVX valve and engine for leaks. If engine does not stop with a leak free system remove intake valve and return to Chalwyn for further investigation.

CHALWYN LIMITED

Chalwyn Industrial Estate, Parkstone, Poole, Dorset BH12 4PF ENGLAND
Tel: +44(0)1202 715200 Fax: +44(0)1202 715600
www.chalwyn.co.uk

CE215-9



CHALWYN LIMITED RESERVE THE RIGHT TO UPDATE THIS PRODUCT SPECIFICATION WITHOUT PRIOR NOTICE.