

Automatic Overspeed Shutdown and Crankcase Breather Kit for Yanmar L40AE, L48AE, L50AE and L70AE Engines

Installation, operation and maintenance

BYL-100

INSTALLATION

1. Remove existing air cleaner assembly complete. Fit Chalwyn adaptor part no.BYL-001 re-using existing engine intake gasket and fasteners.
2. Fit Chalwyn D35BF-35 valve by sliding rubber grommet over the adaptor extension and tightening clamp.
3. Remove engine rocker cover taking care not to damage the gasket. Remove and discard the small rubber plug marked 'Oil'. Prepare aluminium plug BYL-002 for fitting into the breather drilling in the engine rocker cover by applying Loctite 7649 activator and Loctite type 638. Tap plug into the breather drilling until flush with the machined face of the rocker cover flange (see diagram 1).
4. Refit rocker cover.
5. Assemble fittings PS 02 and PS 03 together.

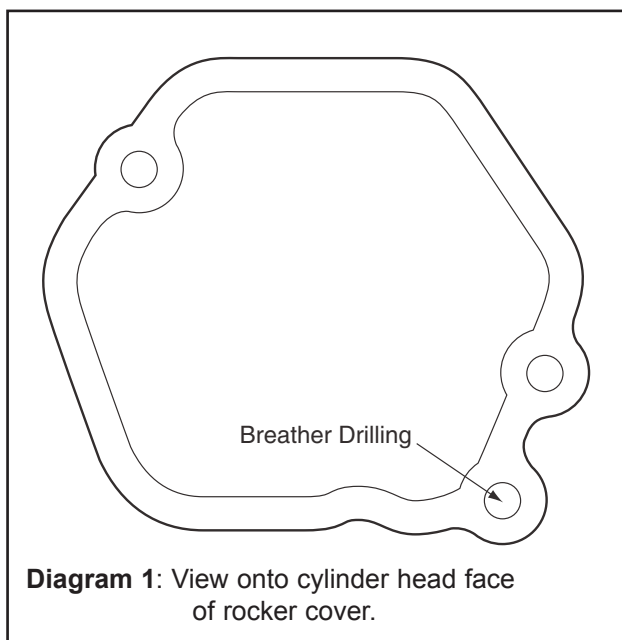

Tighten to make leak proof. Use Loctite 7649 activator and Loctite 638 to secure the shorter of the two 12mm diameter legs of the assembled fittings into the bore at the top of the rocker cover that previously housed the plug marked 'Oil'.

6. Ensure the exposed tail of the assembled fittings points in the direction in which the external breather hose is to run.
7. Fit the 600mm long breather hose supplied to the tail of the fittings using clip JC 02. Secure outlet end of the hose with clip JC 03. Reduce/extend length of breather hose if required.

OPERATION

Adjustment of the Chalwyn shutdown valve is carried out using the adjuster and locknut (refer to diagram 2). Basically rotating the adjuster clockwise will increase the engine speed at which automatic shutdown occurs.

As supplied, the valve will be adjusted such that shutdown will generally occur well below the engine high idle speed. To increase the shutdown speed to the required setting proceed as follows:

1. Start engine. Slowly accelerate. Note speed at which shutdown occurs.
2. Remove the air cleaner cover and element to expose the adjuster and locknut (see diagram2).
3. Release locknut. Turn adjuster clockwise one turn. Tighten locknut.
4. Refit air cleaner cover and element.
5. Start engine. Slowly accelerate. Note speed at which shutdown occurs.
6. Repeat the above steps 2 to 5 until the first setting at which the engine does not shutdown at high idle speed (i.e. maximum throttle, no load). Then either:
 - a) *Use the results of the shutdown speed versus adjuster setting as a calibration check to make the final adjustment to the required setting (typically 10% to 15% over high idle).*
 - or**
 - b) *If a very precise setting is not required, turn the adjuster a further one turn clockwise to take the shutdown above high idle speed by a suitable margin. When using this setting procedure it may be found that the engine occasionally shuts down during its normal operation. If so, turn the adjuster clockwise by a further one half turn.*
7. Ensure the adjuster locknut is fully tightened. Use a thread lock adhesive on the locknut threads.

Note:

Should there be insufficient adjustment to set the shutdown speed at the required level contact your Chalwyn agent for supply of a stronger valve spring.

Diagram 2: Diagram showing D35BF-35 Valve.

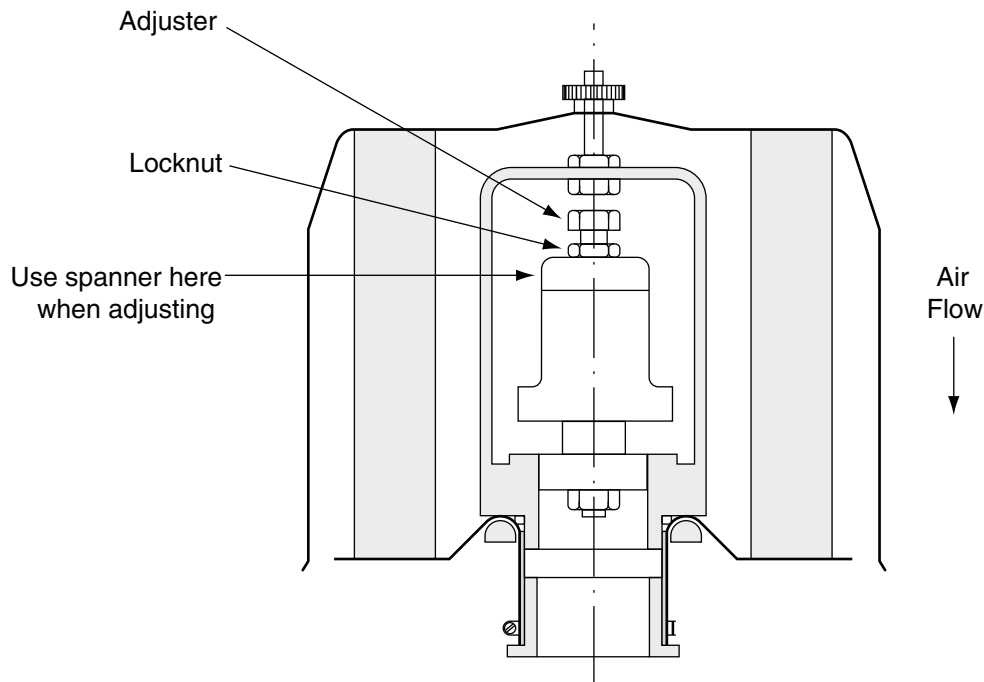

MAINTENANCE

Shutdown Valve and Mechanism

The recommended routine maintenance period is three months. This period is dependent on the operating conditions of the engine and by experience may need to be varied.

Routine Maintenance

1. Slacken retaining clamp to enable the D35BF-35 to be removed from the air intake adaptor.
2. Inspect the valve internally for cleanliness. If necessary, clean in paraffin or white spirit taking normal precautions. Dry the valve thoroughly.
3. Check there is no excessive wear and that the valve moves smoothly over its complete operating stroke.

DO NOT LUBRICATE

4. Refit valve. Check valve setting based on the "Adjustment" instructions given herein.

Note:

When excessive wear is apparent, or the valve damaged, it should be returned to Chalwyn for appraisal and reconditioning.
(All such work is dealt with on a urgent basis.)

Air Cleaner Element

Replace air cleaner element at the periods recommended by the engine manufacturer. Spare elements are available from Chalwyn.



Chalwyn by AMOT

sales@chalwyn.co.uk
www.chalwyn.com

A division of Roper Industries Limited

UK

Western Way
Bury St Edmunds
Suffolk, IP33 3SZ
Tel: +44 (0)1284 715739
Fax: +44 (0)1284 715747

USA

8824 Fallbrook Drive
Houston
TX 77064
Tel: +1 (281) 940 1800
Fax: +1 (713) 559 9419

