

# **SVX-Series Solenoid Actuated Diesel Engine Air Shut Down Valves (Energised to Stop Types)**

## **Selection, Application and Maintenance**

### Valve Numbers

SVX-380, SVX-381, SVX-384, SVX-385

SVX-390, SVX-391, SVX-394, SVX-395

SVX-580, SVX-581, SVX-584, SVX-585

SVX-590, SVX-591, SVX-594, SVX-595

SVX-880, SVX-881, SVX-884, SVX-885

SVX-890, SVX-891, SVX-894, SVX-895

## DESCRIPTION

12vdc and 24vdc diesel engine air intake shut down valves designed for mechanical latching in the open (engine run) position and manual and/or solenoid actuated closure. Based on the standard slimfit Chalwyn 3", 5" and 8" butterfly valves, this product is particularly suited to fire pump and similar applications. It is available in basic flange mounted form or fitted with hose adaptors. Versions with internal microswitches are available to enable valve status indication. The valve bodies and discs are manufactured in corrosion resistant hard anodised aluminium. The spindle and mechanism is made from stainless steel.

### Typical Valve Arrangement - Types with a Manual Shut Down

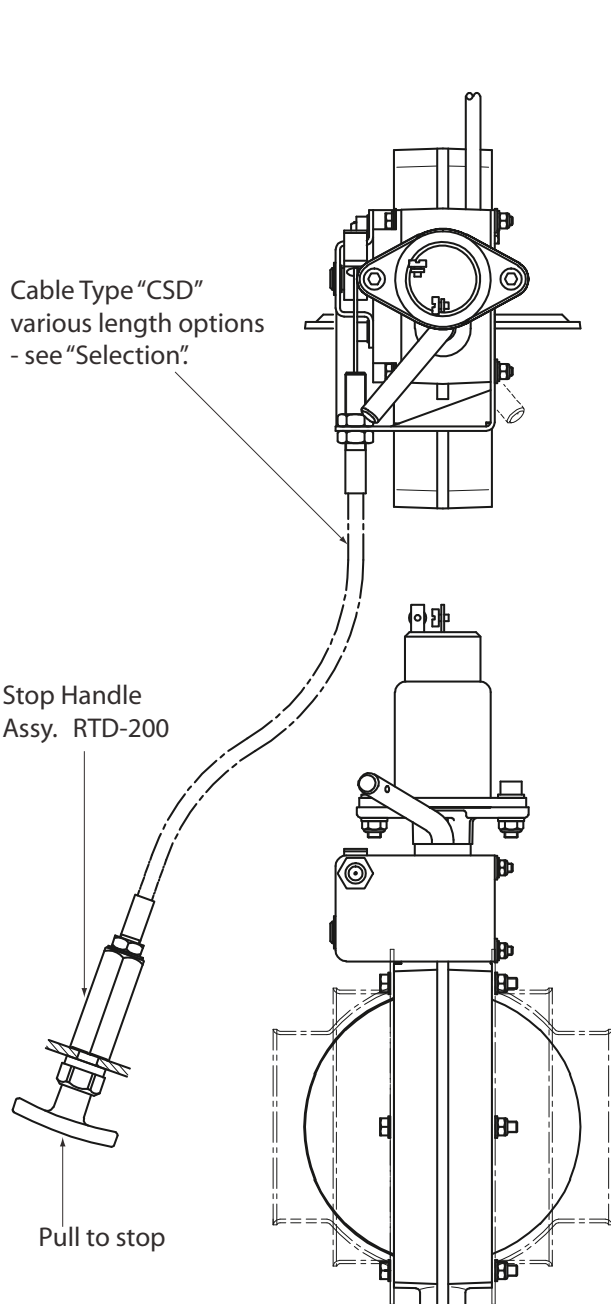

### Typical Valve Arrangement - Types without Manual Shut Down

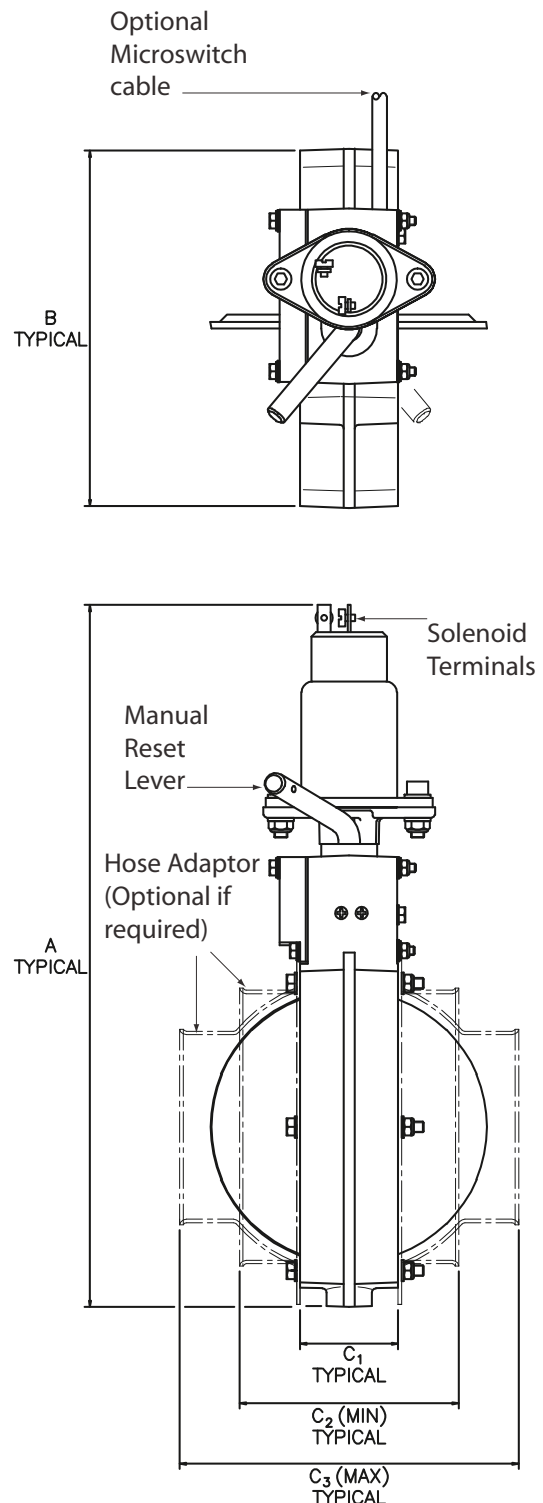

## Main Dimensions (mm) and Features - Valves without Manual Shut Down

Valve Type		Voltage	Nominal Bore Dia.	A	B	C <sub>1</sub>	C <sub>2</sub> (min & max)
With Microswitch	Without Microswitch						
SVX-380	SVX-381	12	76 (3")	270	111.5	37.5	82.5 to 112.5
SVX-390	SVX-391	24	76 (3")	270	111.5	37.5	82.5 to 112.5
SVX-580	SVX-581	12	127 (5")	326	167	45.5	102 to 157.5
SVX-590	SVX-591	24	127 (5")	326	167	45.5	102 to 157.5
SVX-880	SVX-881	12	203 (8")	424.5	257	56.0	136.5 to 185.5
SVX-890	SVX-891	24	203 (8")	424.5	257	56.0	136.5 to 185.5

## Main Dimensions (mm) and Features - Valves with Manual Shut Down

Valve Type		Voltage	Nominal Bore Dia.	A	B	C <sub>1</sub>	C <sub>2</sub> (min & max)
With Microswitch	Without Microswitch						
SVX-384	SVX-385	12	76 (3")	270	111.5	37.5	82.5 to 112.5
SVX-394	SVX-395	24	76 (3")	270	111.5	37.5	82.5 to 112.5
SVX-584	SVX-585	12	127 (5")	326	167	45.5	102 to 157.5
SVX-594	SVX-595	24	127 (5")	326	167	45.5	102 to 157.5
SVX-884	SVX-885	12	203 (8")	424.5	257	56.0	136.5 to 185.5
SVX-894	SVX-895	24	203 (8")	424.5	257	56.0	136.5 to 185.5

### Important Notes

These Chalwyn valves are intended for emergency use. ALWAYS retain an engine fuel stop system for routine shut down.

Maximum temperature of the engine intake air at the SVX valve not to exceed 150°C. [See also "Installation (Mechanical)" - page 4]

## SELECTION

This valve family is suited to applications where a combination of manual latching to the open (engine run) condition with an electrical signal to close is specified. A manual stop option can additionally be specified.

Determine the size and position of the SVX valve to be installed. Within the various constraints imposed by the application, the valve should be as generously sized as possible. Check that the valve can be installed such that the electrical cable can be routed away without risk of damage. Furthermore, if the manual shut down option is also to be specified, determine the route of the shut down cable and then select the required length from the table across. Note that other cable lengths may be available on request.

Determine voltage of valve required. If a valve status indicator is specified, select a valve with an internal microswitch.

Chalwyn 'X' valves are designed for flange mounting. Alternatively these valves can be supplied with fitted hose adaptors selected from the table below.

### Selection Chart - Mechanical Stop Cables.

Cable Part No.	Length (meters)
<b>CSD-100</b>	<b>1.0</b>
<b>CSD-150</b>	<b>1.5</b>
<b>CSD-200</b>	<b>2.0</b>
<b>CSD-300</b>	<b>3.0</b>

## Hose Adaptor Options

76mm (3") Bore Valves	
Adaptor Part Number	To Suit Hose Bore mm (inches)
HAX-320	38 (1½)
HAX-322	44.5 (1¾)
HAX-301	51 (2)
HAX-302	54 (2 ⅙)
HAX-303	57 (2 ¼)
HAX-304	60 (2 ⅜)
HAX-305	63.5 (2 ½)
HAX-306	67 (2 ⅝)
HAX-307	70 (2 ¾)
HAX-308	73 (2 ⅞)
HAX-309	76 (3)
HAX-312	82.5 (3¼)
HAX-314	89 (3 ½)
HAX-319	102 (4)

127mm (5") Bore Valves	
Adaptor Part Number	To Suit Hose Bore mm (inches)
HAX-501	89 (3 ½)
HAX-502	92 (3 ⅝)
HAX-503	95 (3 ¾)
HAX-504	98 (3 ⅞)
HAX-505	102 (4)
HAX-506	105 (4 ⅙)
HAX-507	108 (4 ¼)
HAX-508	111 (4 ⅜)
HAX-509	114 (4 ½)
HAX-510	117.5 (4 ⅝)
HAX-511	121 (4 ¾)
HAX-512	124 (4 ⅞)
HAX-513	127 (5)
HAX-518	140 (5 ½)
HAX-523	152 (6)

203mm (8") Bore Valves	
Adaptor Part Number	To Suit Hose Bore mm (inches)
HAX-807	178 (7)
HAX-808	203 (8)

## INSTALLATION (MECHANICAL)

1. Valves which include the manual shut down option are supplied complete with the manual stop cable and 'T' handle fitted and adjusted. Do not separate the cable from handle or valve (see paragraph 9).
2. In the case of a naturally aspirated engine, the Chalwyn SVX shut down valve should generally be fitted as close to the engine air intake manifold as possible. If an air intake flame trap is also fitted, the SVX valve must be installed upstream (air cleaner side) of the flame trap.
3. To avoid excessively high intake air temperature at the SVX valve when fitted to a turbocharged engine, it may be necessary to fit the valve either upstream of the turbocharger or downstream of the intercooler (if fitted). Again, if an air intake flametrap is also fitted, the valve must be installed upstream of the flametrap.
4. Where more than one SVX valve is installed on an engine, as in the case of an engine with multiple intake pipes, the shut down valve control system must be arranged to ensure all valves close simultaneously.
5. This valve may be installed either horizontally or vertically.
6. If hose adaptors are used, the mating hose should be of a reinforced type, provide adequate support for the valve and prevent excessive vibration. If necessary, additional support brackets mounted from the engine should be considered.
7. Particular care must be taken to ensure the integrity of the intake pipework between the Chalwyn valve and intake manifold. Ideally metal pipework should be used and any gaps kept as short as possible, (taking into account any relative movement,) and closed by reinforced hose.
8. Any engine crankcase breather connections into the intake system between the SVX valve and engine, or any internal crankcase breather arrangement venting directly into the engine intake ports must be sealed and replaced by an external breather system venting either to atmosphere or to the intake system upstream of the shut down valve. External breather system kits for various engine types are available from Chalwyn.
9. Valves fitted with manual shut down handle assembly RTD-200. Prepare a  $\text{Ø}10\text{mm}$  ( $\frac{3}{8}$ " ) hole in the panel/bracket to which the stop control is to be mounted. Release the handle locknut. Remove the handle, handle lock nut and mounting nut. Offer up the RTD-200 body to the back face of the panel/bracket allowing the internal rod of the RTD-200 to project through the prepared hole. Refit the mounting nut and fully tighten. Refit handle locknut winding as far as possible onto the threaded rod. Refit handle winding hard down onto the locknut and then tightening locknut onto the handle. Note during this operation the handle and locknut will need to be held out against the valve spring return load.

### Handle Assembly Type RTD-200

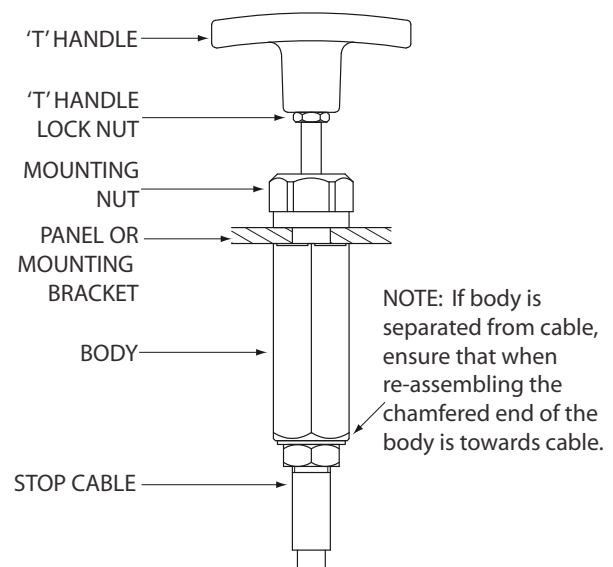

## INSTALLATION (Electrical)

The actuating solenoid is a two wire type with internal switching from pull to hold current. On supply of power, the full pull current is drawn for less than 1 second before switching to the hold current. Once the valve has closed the power supply to the solenoid can be removed at any time. The valve will not re-open until manually reset.

### Electrical Data for the Solenoid

Valve Model	SVX-380 SVX-381 SVX-384 SVX-385 SVX-580 SVX-581 SVX-584 SVX-585 SVX-880 SVX-881 SVX-884 SVX-885	SVX-390 SVX-391 SVX-394 SVX-395 SVX-590 SVX-591 SVX-594 SVX-595 SVX-890 SVX-891 SVX-894 SVX-895
Supply voltage	12 vdc	24 vdc
Pull current	46 amps	25 amps
Hold current	1.1 amps	0.5 amps
Max. length for supply cable (2.5mm <sup>2</sup> )	2.7m	10m
Max. length for supply cable (4.0mm <sup>2</sup> )	4.2m	16m

Valve models SVX-380, SVX-384, SVX-390, SVX-394, SVX-580, SVX-584, SVX-590, SVX-594, SVX-880, SVX-884, SVX-890 and SVX-894 have a built-in microswitch. This enables an indication of the valve open/close status. The microswitch connections are made as follows:-

Brown : Supply - common

Blue : Makes circuit when valve is closed

Black : Makes circuit when valve is open. (Was yellow/green on early models.)

Maximum rating of microswitch at 12 or 24 volts = 2 amp

## OPERATION

Prior to starting the engine, the SVX valve must be latched open by rotating the manual reset lever clockwise as far as possible. Additionally, if the manual stop option is fitted, ensure that the stop handle is pushed inwards to the run (valve open) condition.

Once latched, the reset lever will remain in the open position until either released by the action of the solenoid to close the valve or, where fitted, by the operation of the valve's manual stop control.

Normal engine shut down via the fuel stop will not result in the Chalwyn valve closing.

---

## MAINTENANCE

### WEEKLY:

Visually check the valve, solenoid and cables for damage or deterioration. Withdraw from service if significant damage or deterioration is observed.

### MONTHLY:

1. Check that the fasteners locating the shut down valve and any associated intake system or support bracket fasteners are securely tightened.
2. Check that any flexible hoses in the engine intake between the SVX valve and engine are free from damage and suitable for further service.
3. Run engine, preferably at low idle. Apply the appropriate voltage to the solenoid to close the intake shut down valve. The engine should stop within a few seconds. If not, check there are no leaks in the engine air intake system between the SVX valve and engine. If this does not resolve the problem remove the SVX valve to return to Chalwyn for investigation.
4. If the manual stop option is fitted to the valve, repeat '3' above but using the manual intake valve stop. Again the engine should stop within a few seconds.



**Chalwyn by AMOT**

sales@chalwyn.co.uk  
www.chalwyn.com

A division of Roper Industries Limited

**UK**

Western Way  
Bury St Edmunds  
Suffolk, IP33 3SZ  
Tel: +44 (0)1284 715739  
Fax: +44 (0)1284 715747

**USA**

8824 Fallbrook Drive  
Houston  
TX 77064  
Tel: +1 (281) 940 1800  
Fax: +1 (713) 559 9419

