



# **SVX-Series Diesel Engine Shut Down Valves**

**(Solenoid Latched Types with Manual Start Override/Emergency Stop)**

**Selection, Application and Maintenance**

Valve Numbers	
SVX-340	SVX-350
SVX-341	SVX-351
SVX-540	SVX-550
SVX-541	SVX-551

## DESCRIPTION

12 and 24 vdc solenoid powered diesel engine shut down valves based on the standard 3" and 5" slimfit Chalwyn butterfly valves. Designed for applications where no suitable electrical supply is available during engine start up and a manual override facility is therefore required. Once the protected engine is running and electrical power is available the valve is latched in the open (run) position by the solenoid until power is lost or until the manual emergency shut down facility is operated. These valves are available in flange mounted form or can be supplied fitted with hose adapters and/or a flametrap housing.

Versions of these valves are available for both hazardous and non-hazardous area application. Valve bodies and discs are manufactured in corrosion resistant hard anodised aluminium with PTFE coating. The valve spindle is made from 316 grade stainless steel.

### Typical Valve Arrangement

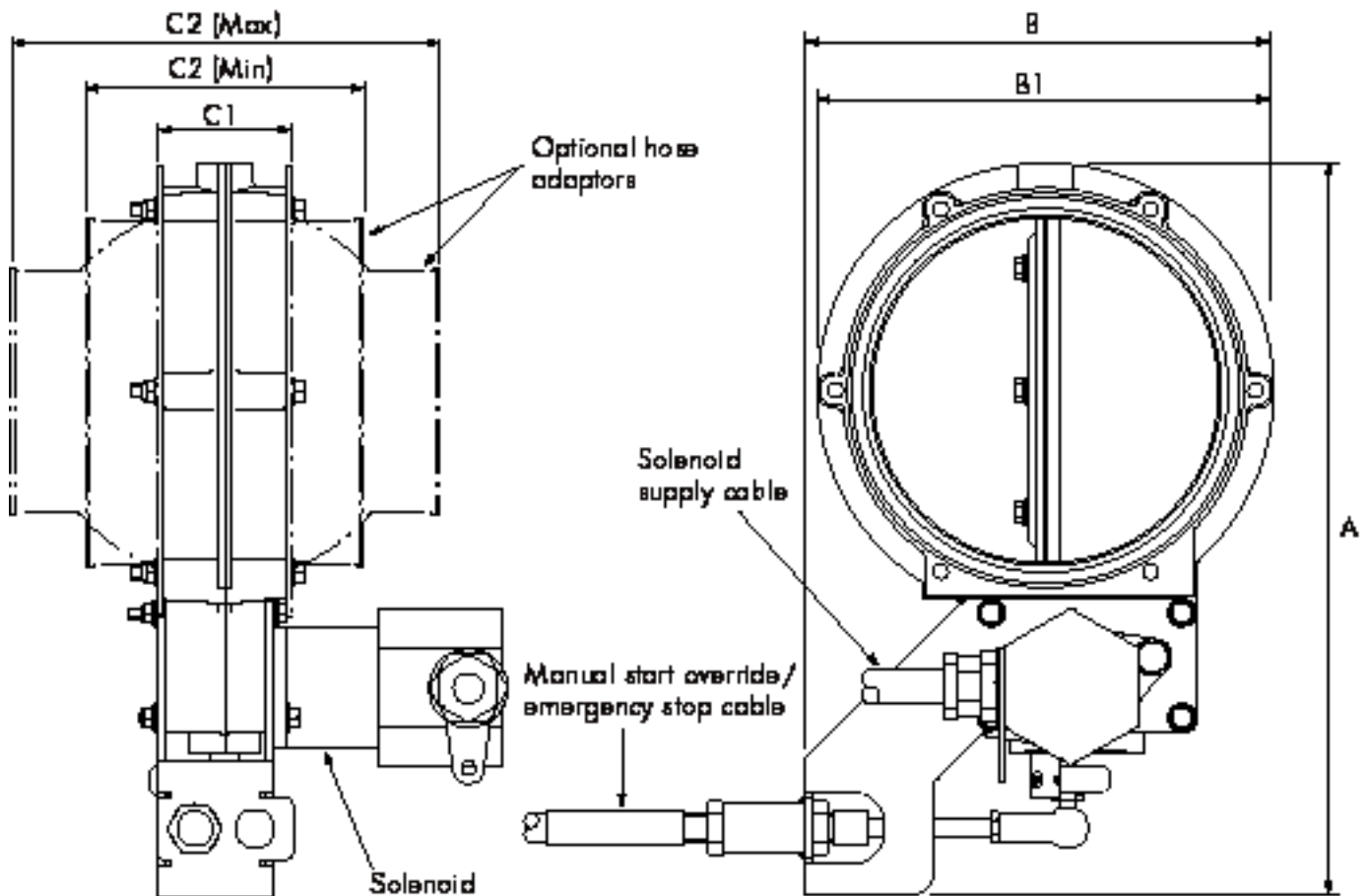
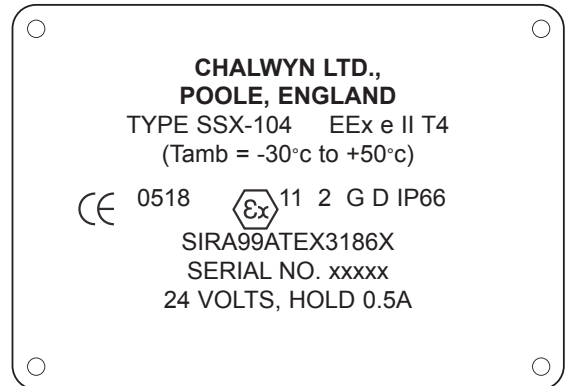
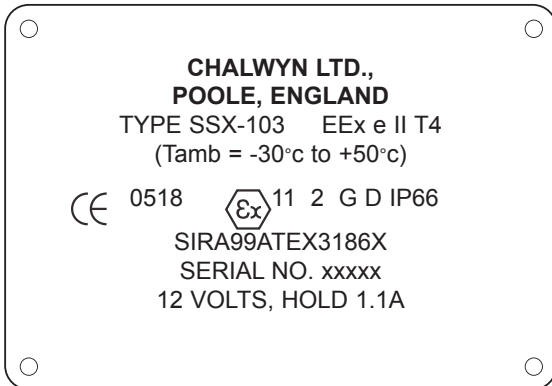

Illustration based on SVX-540

### Main Dimensions (mm)

Valve Type	Nominal Bore Diameter	A mm	B mm	B1 mm	C1 mm	C2 minimum & maximum
SVX-340 SVX-341 SVX-350 SVX-351	76 (3")	213.5	111.5	144	37.5	82.5 to 112.5
SVX-540 SVX-541 SVX-550 SVX-551	127 (5")	270	167.25	172	45.5	101.9 to 157.5

The Chalwyn solenoid SSX-103 and SSX-104 built into the hazardous area valves type SVX-340, SVX-341, SVX-540 and SVX-541 are marked as follows:



**IMPORTANT NOTES: SOLENOID TYPE SSX-103 and SSX-104**

Araldite epoxy adhesive and an elastomeric cable seal are used in the construction of these solenoids. The characteristics of these materials with regard to attack by aggressive substances shall be taken into account when installing or using the product in a hazardous area.

Solenoids SSX-103 and SSX-104 must not be mounted or installed in such a way that the effective ambient temperature exceeds 50°C.

## SELECTION

Valve types SVX-340, SVX-341, SVX-540 and SVX-541 are suitable for installation in Zone I, Group IIB, T4 hazardous areas. Valve types SVX-350, SVX-351, SVX-550 and SVX-551 are not suitable for hazardous area application.

Determine the size and position of the SVX valve to be installed. Check that the electrical cable can be routed away without risk of damage. Alternative entry points are available for the cable (check with Chalwyn). Identify a suitable position for the start override lever (RLX-100) which is both convenient for operation and permits a reasonably straight run for the start override cable to the SVX valve. Start override cables are available from stock in the lengths shown below. Other sizes available on request.

SVX valves are designed for mounting between flanges but can also be supplied complete with fitted hose adaptors selected from the table below.

### Hose Adaptor Options

76mm (3") Bore Valves	
Adaptor Part Number	To Suit Hose Bore mm (inches)
HAX-320	38 (1½)
HAX-322	44.5 (1¾)
HAX-301	51 (2)
HAX-302	54 (2 ⅙)
HAX-303	57 (2 ¼)
HAX-304	60 (2 ⅜)
HAX-305	63.5 (2 ½)
HAX-306	67 (2 ⅝)
HAX-307	70 (2 ¾)
HAX-308	73 (2 ⅞)
HAX-309	76 (3)
HAX-312	82.5 (3¼)
HAX-314	89 (3 ½)
HAX-319	102 (4)

127mm (5") Bore Valves	
Adaptor Part Number	To Suit Hose Bore mm (inches)
HAX-501	89 (3 ½)
HAX-502	92 (3 ⅝)
HAX-503	95 (3 ¾)
HAX-504	98 (3 ⅞)
HAX-505	102 (4)
HAX-506	105 (4 ⅙)
HAX-507	108 (4 ¼)
HAX-508	111 (4 ⅜)
HAX-509	114 (4 ½)
HAX-510	117.5 (4 ⅝)
HAX-511	121 (4 ¾)
HAX-512	124 (4 ⅞)
HAX-513	127 (5)
HAX-518	140 (5 ½)
HAX-523	152 (6)

### Override Cable Options

Cable Identity	Cable Length
CHW-100	1.0m
CHW-200	2.0m
CHW-250	2.5m
CHW-300	3.0m

## INSTALLATION (Mechanical)

1. In the case of a naturally aspirated engine, the Chalwyn SVX shut down valve should generally be fitted as close to the engine air intake manifold as possible. If an intake flame trap is also fitted, the SVX valve must be installed upstream (air cleaner side) of the flame trap.
2. To avoid excessively high temperatures at the SVX valve when fitted to a turbocharged engine, it is recommended the valve is fitted either upstream of the turbocharger or downstream of the intercooler (if fitted). Again, if an air intake flametrap is also fitted, the valve must be installed upstream of the flametrap.
3. SVX intake shut down valves may be installed either horizontally or vertically. Air flow may be in either direction.
4. Position the SVX valve such that the electrical and mechanical cables can be routed away clear of any hot or sharp surface.
5. If hose adaptors are used, the mating hose should be of a re-inforced type, provide adequate support for the valve and prevent excessive vibration. If necessary, additional support brackets mounted from the engine should be considered.
6. Particular care must be taken to ensure the integrity of the intake pipework between the Chalwyn valve and intake manifold. Ideally metal pipework should be used and any gaps kept as short as possible, (taking into account any relative movement) and closed by reinforced hose. The possibility of a hose collapse on closure of the shut down valve should be avoided.
7. Any engine crankcase breather connections into the intake system between the SVX valve and engine, or any internal crankcase breather arrangement venting directly into the engine intake ports must be sealed and replaced by an external breather system venting either to atmosphere or to the intake system upstream of the shut down valve. External breather system kits for various engine types are available from Chalwyn.
8. The lever assembly RLX-100 should be mounted using the three through holes provided in the assembly. It must be positioned where convenient for operation and also to permit a reasonably straight run without tight bends for the override cable between the lever assembly and valve.
9. The lever RLX-100 is sprung towards the valve closed position. With no power applied the SVX valve is also sprung to the closed position. With both the RLX-100 and SVX valve in the closed position fit the override cable. Adjust cable and tighten the locknuts such that with the SVX valve fully closed, the outboard end of the lever RLX-100 is positioned about 5 to 10mm from its central stop (closed) position. When the RLX-100 is exercised over its operating stroke the distinct sound of the SVX valve closing should now be audible.

## INSTALLATION (Electrical)

Valve Type	Specification	Power Rating		Cable Colour	
		V	A	Hold	Common
SVX-340 SVX-540	EExe II T4	12	1.1	Brown	Blue
SVX-341 SVX-541	EExe II T4	24	0.5	Brown	Blue
SVX-350 SVX-550	Non Flameproof	12	1.1	Red	Black
SVX-351 SVX-551	Non Flameproof	24	0.5	Red	Black

Subject to the valve type, either a 12volt or 24volt supply is required to energise the solenoid to latch the valve in the run (open) position (see above). When de-energised the SVX valve will always return to the closed position except when overridden by the manual start override. The electrical supply to the solenoid must be arranged/operated such that power is not applied to the SVX valve until it is held open by the manual start override.

In the case of the hazardous area valves SVX-340,

SVX-341, SVX-540 and SVX-541 the outer braiding of the supply cable must be earthed at the supply end. The solenoid end cover should be earthed using the earth tag of the cable gland. The electrical supply system for the hazardous area type valves must be suitable for the hazardous environment of the application and appropriate glanding used at the supply end of the solenoid cable. Clamping devices should be fitted to the cable as close as possible to the glands.

## OPERATION

1. Prior to starting engine use the start override lever to open the SVX valve to the run position.
  2. Continue to hold the valve in the run position whilst starting and running up engine.
  3. As soon as the appropriate electrical supply is available at the SVX solenoid, the valve will latch in the run position. The override lever may then be released and should remain in the run position.
  4. If at any time the electrical supply to the solenoid is lost the SVX valve will close and stop the engine.
  5. To carry out a manual emergency stop, move the start override lever from the run position back to the stop (valve closed) position.
- Note.** Only apply power to the SVX valve solenoid after the SVX valve has first been opened by the start override control.

## MAINTENANCE

---

### MONTHLY:

Check that the fasteners locating the SVX valve and any associated intake system or support bracket fasteners are tight.

Check that any flexible hoses in the air intake system between the SVX valve and engine are free from damage and suitable for further service.

Check that the electrical cable to the valve is properly clamped/supported and free from damage.

Start engine. Run at or just above low idle speed. Carry out a manual emergency stop. The engine should stop within a few seconds of moving the start override lever from the run to stop position. If not:

- a) Check then engine air intake system for freedom from leaks.
- b) Check that the start override cable is properly adjusted.

Should these checks not resolve the problem return the SVX valve to Chalwyn for inspection.



**Chalwyn by AMOT**

sales@chalwyn.co.uk  
www.chalwyn.com

A division of Roper Industries Limited

**UK**

Western Way  
Bury St Edmunds  
Suffolk, IP33 3SZ  
Tel: +44 (0)1284 715739  
Fax: +44 (0)1284 715747

**USA**

8824 Fallbrook Drive  
Houston  
TX 77064  
Tel: +1 (281) 940 1800  
Fax: +1 (731) 559 9419

