

CHALWYN

DIESEL PROTECTION SYSTEMS

**D200 Spindle Type
Automatic Engine Overspeed
Air Intake Shut Down Valve**
(Including Manual, Oil and Air Pressure
Shut Down Control Options)

SELECTION, APPLICATION AND MAINTENANCE

Valve Numbers		
D200	D200S	D200SX
D200-AM	D200S-AM	D200SX-AM
D200-AP	D200S-AP	D200SX-AP
D200-AMP	D200S-AMP	D200SX-AMP
D200-AMZ	D200S-AMZ	D200SX-AMZ

DESCRIPTION

The D200 is a spring loaded poppet valve designed to automatically stop an engine by closing down the air intake should excessive overspeeding occur.

Three basic build options are available. The D200 has standard springs, the D200S strong springs and the D200SX extra strong springs. The initial selection of the springs is determined by the rating of the engine to which the valve is to be fitted.

Versions of this valve are also available with the addition of various combinations of manual, oil and air pressure operated shut down options.

The closing force on the valve is provided by the intake air flow passing through. As the air flow increases, the closing force builds up. This is resisted

by the valve springs, the pre-load on which is adjustable such that at a given air flow the resulting force overcomes the spring resistance and causes the valve to close. Once closed the valve will not reset to the open condition until the engine stops.

This type of valve may be fitted to either naturally aspirated or turbocharged engines. It should be noted however that for a given valve setting the repeatability of the actual shut down speed has a greater scatter in the case of a turbocharged engine. However, unless for special reasons a precisely repeatable shut down speed is required, adequate protection from excessive overspeed and potential resulting damage is still achieved.

D200, D200S, D200SX

The main dimensions of the D200 family of valves are given below. Weight is approximately 10.5kg.

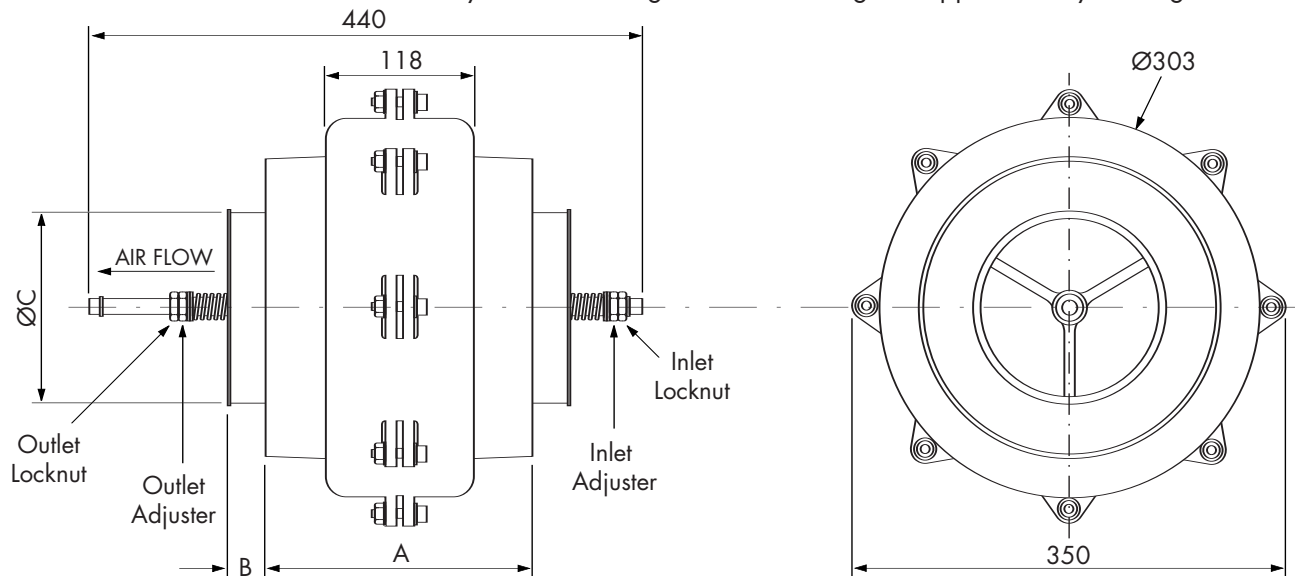

	Basic Valves (No Cable Connections)	Valves with Cable Connections	All Types
For $\varnothing C$ between 152mm and 187mm	$A = (360 - \varnothing C)$ mm	$A = (360 - \varnothing C)$ mm	$B = 32$ mm
For $\varnothing C$ between 188mm and 209mm	$A = (360 - \varnothing C)$ mm	$A = (266 - \varnothing C/2)$ mm	$B = 32$ mm
For $\varnothing C$ between 210mm and 229mm	$A = 124$ mm	$A = 148$ mm	$B = 40$ mm

* $\varnothing C$ may be selected from within the range 152mm(6") to 229mm(9") in 1mm steps to match the engine intake pipework. See page 4 "SELECTION".

D200-AM, D200S-AM, D200SX-AM

The basic valve dimensions are as given for the D200. Select length of manual shut down cable required from table on page 4.

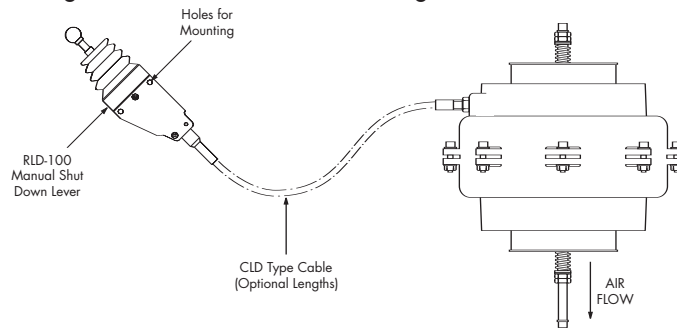

D200-AP, D200S-AP, D200SX-AP

The basic valve dimensions are as given for the D200. Requires a CLEAN, DRY air pressure supply between 4 bar (60 psi) and 8 bar (120 psi) to operate the air pressure shut down.

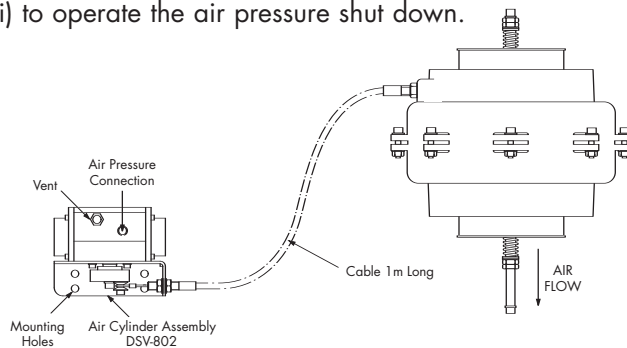

D200-AMP, D200S-AMP, D200SX-AMP

The basic valve dimensions are as given for the D200. Select length of manual shut down cable type 'CLE' required from table on page 4. Requires a CLEAN, DRY air pressure supply between 4 bar (60psi) and 8 bar (120 psi) to operate the air pressure shut down.

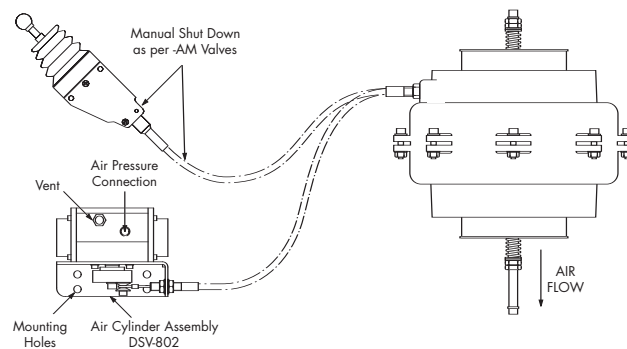

D200-AMZ, D200S-AMZ, D200SX-AMZ

The basic valve dimensions are as given for the D200. Select length of manual shut down cable TYPE 'CHW' required from the table on page 4. Valve closure occurs if the oil (or air) pressure input falls below 1bar approx. (14.5psi).

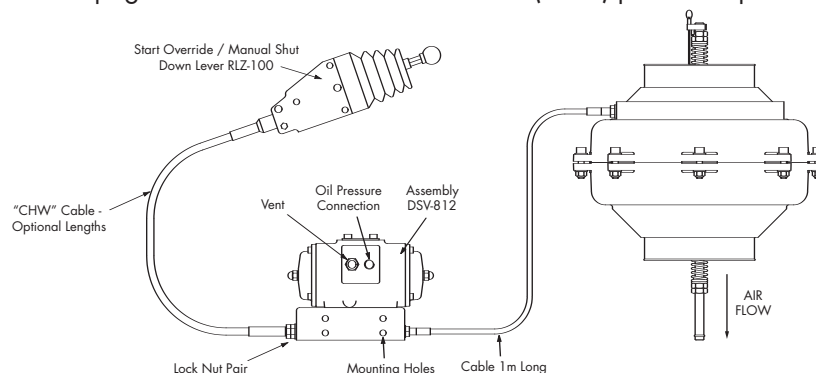

SELECTION

1. From the table across select the valve type to suit the power output of the engine. Note, the recommended power ranges are applicable to all variants of each valve type.

VALVE TYPE	ENGINE POWER AT RATED SPEED
D200	270 to 306 kW (362 to 410 hp)
D200S	307 to 455 kW (411 to 610 hp)
D200SX	456 to 600 kW (611 to 805 hp)

2. Select the end diameters of the valve from the range available to match the bore of the engine air intake hose into which the valve is to be fitted - see ØC page 2 - DESCRIPTION

3. For "-AM" and "-AMP" valves use the table across to select the length of cable required for the manual shut down function.
Also order lever RLD-100.
Note: Other cable lengths may be available on request.

CABLE PART N°	LENGTH (Metres)
CLE-100	1.0
CLE-150	1.5
CLE-200	2.0
CLE-300	3.0

4. For "-AMZ" valves use the table across to select the length of cable required for the manual control functions.
Also order lever RLZ-100
Note: Other cable lengths may be available on request.

CABLE PART NO	LENGTH (Metres)
CHW-150	1.5
CHW-200	2.0
CHW-300	3.0
CHW-400	4.0

Note:

For smaller versions of all valve options covered herein, please see Chalwyn Data Sheets CE 204 to CE 210, CE 237, CE 238 and CE 243.

FITTING

1. If the valve is type "-AM", "-AP", "-AMP" or "-AMZ", the mechanical shut down cable, shut down lever and, where applicable, the shut down cylinder assembly are supplied assembled to the valve with all adjustments completed. It is recommended that these assemblies are not separated during fitting.
2. The Chalwyn valve is designed for fitting as close to the engine air intake manifold as possible. Where an engine air intake flametrap is also fitted, the Chalwyn valve must always be positioned immediately on the upstream (air cleaner) side of the flametrap. These same requirements are generally applicable to both naturally aspirated and turbocharged engines but in the case of a turbocharged engine the following may be applicable.
 - a) Insufficient space to fit between the turbocharger and engine. In this case the valve may be fitted upstream of the turbocharger.
 - b) The turbocharger air outlet temperature is exceptionally high (200°C plus) In this case fit the valve downstream of the intercooler or upstream of the turbocharger.
3. Valves with mechanical cables must also be positioned to enable a reasonably straight run for the cables.
4. When fitting, the direction of the air flow arrow on the Chalwyn valve must be observed. The valve may be installed either horizontally or vertically. The cuffs at the inlet and outlet of the valve should be of a reinforced type, provide adequate support for the valve and prevent excessive vibration. If necessary, additional support brackets mounted from the engine should be considered.
5. Where more than one Chalwyn valve is fitted to an engine as in the case of an engine with multiple intake pipes, a balance pipe arrangement must be installed to connect the various intake pipes together downstream (engine side) of the shut down valves. Typically balance pipe diameters should be about 30% of the diameter of the intake pipes.
6. Particular care must be taken to ensure the integrity of the intake pipework between the Chalwyn valve and intake manifold. Ideally metal

Note. Ensure that, when fitted immediately upstream of the turbocharger, the valve spindle does not project into the turbocharger when the valve closes.

pipework should be used and any gaps kept as short as possible, (taking into account any relative movement) and closed by reinforced hose. The possibility of a hose collapse on closure of the shut down valve should be avoided.

7. Any engine crankcase breather connections into the intake system between the Chalwyn valve and engine, or any internal crankcase breather arrangement venting directly into the engine intake ports, must be sealed and replaced by an external breather system venting either to atmosphere or to the intake system upstream of the shut down valve.
8. Valves with manual control levers. A suitable bracket is required to enable installation of the manual lever assembly in a convenient position. Keep the mechanical cable run as straight as possible avoiding any sharp bends.
9. Valves with air pressure operated shut down.
 - a) Securely locate the cylinder assembly in a convenient position using the mounting holes provided. Avoid any sharp bends in the cable run.
 - b) Connect the CLEAN, DRY shut down air supply to the inlet port of the shut down valve cylinder. The air exhaust port should also be piped back to clean, dry air to avoid moisture or dust being drawn back into the air cylinder. Note. A shut down air supply pressure of 4 bar (60 psi) to 8 bar (120 psi) is required to operate the shut down.
10. Valves with shut down on loss of oil (or air) pressure.
 - a) Securely locate the cylinder assembly in a convenient position using the mounting holes provided. Avoid any sharp bends in the cable run.
 - b) Connect the oil (or air) pressure supply to the shut down cylinder. Note: the valve will shut down if the supply pressure falls below about 1 bar (14.5psi).
The maximum pressure supply should not exceed 8 bar (120 psi).

Important Notes:

In addition to the air intake shut down valve, an engine fuel stop must always be retained to enable normal engine shut down. ie. DO NOT use the emergency manual shut down lever as the normal way to stop the engine in a non emergency situation.

OPERATION

Engine Start “-AMZ” Valves

RLZ-100 start override/emergency stop lever must be held in the “start override” position prior to starting the engine. Continue to hold this lever in the start override (engine run) position after starting the engine until it latches in this position (may take up to about 30 seconds if engine oil pressure is the operating fluid). Release lever.

Engine Stop

Use normal engine fuel stop.

Emergency Manual Stop

Move the start override/emergency stop lever firmly to the stop position.

Note: Start override/emergency stop lever RLZ-100 always returns to the “stop” position when the engine is not running.

ADJUSTMENT

Once the Chalwyn valve is installed, adjustment of the overspeed trip setting is carried out using the inlet adjuster and locknut (refer to diagram). Basically rotating the inlet adjuster clockwise will increase the engine speed at which automatic shut down occurs.

As supplied, the valve will be adjusted such that shut down will generally occur below the engine high idle speed. To increase the shut down speed to the required setting proceed as follows:-

Note. Prior to carrying out the following adjustments check that, where fitted, the manual and air pressure shut down controls are in the “run” condition. In the case of “-AMZ” valves start the engine as given under “Operation”.

1. Start engine. Slowly accelerate. Note speed at which shut down occurs.
2. Remove hose at **air inlet** to Chalwyn valve to expose the adjuster and locknut (see diagram).
3. Release locknut. Turn adjuster clockwise one turn. Tighten locknut.
4. Refit inlet hose to Chalwyn valve.
5. Start engine. Slowly accelerate. Note speed at which shut down occurs.
6. Repeat the above steps ‘2’ to ‘5’ until the first setting at which the engine does not shut down at high idle speed (i.e. maximum throttle, no load). Then either:
 - a) Use the results of shut down speed versus adjuster setting as a calibration check to make a final adjustment to give the required setting (typically 10% to 15% over high idle).
 - or**
 - b) If a very precise setting is not required, turn the adjuster a further one turn clockwise to take the shut down above high idle speed by a suitable margin. When using this setting procedure it may be found that the engine occasionally shuts down during its normal operation. If so, turn the adjuster clockwise by a further one half turn.
7. Ensure the adjuster locknut is fully tightened. (Use a thread lock adhesive on the locknut threads).
8. Where fitted, and after completing the valve overspeed trip adjustment, check the functioning of the oil/air pressure shut down and, or, manual shut down by operating each in turn with the engine running at medium speed. The engine should stop within a few seconds in each case.

ADJUSTMENT Continued

Notes:

Adjustment of Mechanical Cables.

a) Air pressure shut down cylinder to valve ('-AP' and '-AMP' types). This is adjusted such that when operated by applying pressure with the engine NOT running, the valve disc moves to within about 1 mm of the valve seat DO NOT adjust such that the air cylinder pulls the valve fully on to its seat.

b) Oil (or Air) pressure shut down cylinder to valve ("-AMZ types). This is adjusted such that with the engine NOT running and zero oil (or air) pressure, the valve is held between 0mm and 1mm open. DO NOT adjust such that with zero oil (or air) pressure the shut down cylinder return spring is pulling the valve hard onto its seat.

c) Manual lever to valve ('-AM" and "-AMP" types) Adjusted to operate the full stroke of the valve (Note: it takes considerable force to manually close the valve when the engine is not running. This is a design feature and adjustment is not necessary. Once the engine is running less force is required to give a shut down).

d) Manual lever to oil shut down cylinder ("-AMZ" types). Adjusted to operate via the shut down cylinder assembly to give the full stroke of the valve.

Insufficient Overspeed Adjustment.

Should there be insufficient adjustment available to set the required overspeed trip point, the outlet locknut should be released and the outlet adjuster rotated anticlockwise by four turns. The outlet locknut should then be treated with a thread lock adhesive and securely tightened. Further adjustment to the inlet adjuster as per above instructions is then continued.

Turbocharged Engines.

When setting up a valve on a turbocharged engine using the preceding method, it may be found that at high power outputs, the engine will shut down at a lower speed than required. If this occurs, further small adjustments in steps of one half turn clockwise should be made until the problem is eliminated.

MAINTENANCE

Routine maintenance should be undertaken as follows :-

Daily: Once per day carry out the checks 7 and 8 listed under “Three Monthly” as applicable to the valve model type. In each case the engine should stop within a few seconds.

Three Monthly:

1. For “-AMZ” valves check the shut down cylinder assembly for freedom from leakage. Any leakage must be rectified prior to returning the valve to service.
2. Disconnect intake pipework and remove valve complete with any attached cables, shut down cylinder, manual actuation lever.
3. Inspect the valve internally for cleanliness. If necessary, clean in paraffin or white spirit taking normal precautions. Dry the valve thoroughly.
4. Check there is no excessive wear and that the valve moves smoothly over its complete operating stroke. **DO NOT LUBRICATE.**
5. Check adjustment of mechanical cables (see Page 7)
6. Refit valve. Check valve overspeed trip setting based on the “Adjustment” instructions given herein.
7. With the engine running at medium speed operate the manual shut down lever (when fitted). The engine should stop within a few seconds.
8. For ‘-AP” and ‘-AMP” valve types run the engine at medium speed and then apply a shut down air pressure signal of about 5 bar (70 psi). The engine should stop in a few seconds.
9. For “-AMZ” Valve types run the engine at medium speed and then exhaust the shut down oil (or air) pressure. The engine should stop within a few seconds
10. Check over all pipework for security and freedom from leakage

Note: If the valve fails to function correctly, or if there is any doubt about the operation of the valve, it should be withdrawn from service until corrective action has been completed.

Important Notes:

The three monthly routine maintenance period requirement is dependent on the operating conditions to which the equipment is exposed and, by experience, may need to be varied.

Any maintenance problems not covered by the routine maintenance schedule should be discussed with your Chalwyn Distributor before any repair work is undertaken.

CHALWYN LIMITED

Chalwyn Industrial Estate, Parkstone, Poole, Dorset BH12 4PF ENGLAND

Tel: +44(0)1202 715200 Fax: +44(0)1202 715600

www.chalwyn.co.uk

