



D-Series Engine Automatic Overspeed Shut Down Valves

**(Spindle Types with Air Pressure and Manual
Shut Down Options)**

Selection, Application and Maintenance

Valve Numbers

D92-AP D102-AP D121-AP D136-AP
D92-AMP D102-AMP D121-AMP D136-AMP

DESCRIPTION

A range of spring loaded poppet valves designed to automatically stop an engine by closing down the air intake should excessive overspeeding occur. These valves also include a port to receive an air pressure signal to close the valve. Additionally a manually actuated shut down version can be supplied.

These valves are available with standard springs or strong springs (indicated by the suffix "S" after the valve type number). The spring selection is determined by the rating of the engine to which the valve is to be fitted.

The closing force on the valve is provided by the intake air flow passing through. As the air flow increases, the closing force builds up. This is resisted by the valve springs, the pre-load on which is adjustable such that at a given air flow the resulting force overcomes the spring resistance and causes the valve to close. Once closed the valve will not reset to the open condition until the engine stops.

This type of valve may be fitted to either naturally aspirated or turbocharged engines. It should be noted that for a given valve setting the repeatability of the actual shut down speed has a greater scatter in the case of a turbocharged engine. However, unless for special reasons a precisely repeatable shut down speed is required, adequate protection from excessive overspeed and potential resulting damage is still achieved.

The basic dimensions for this family of valves is given below.

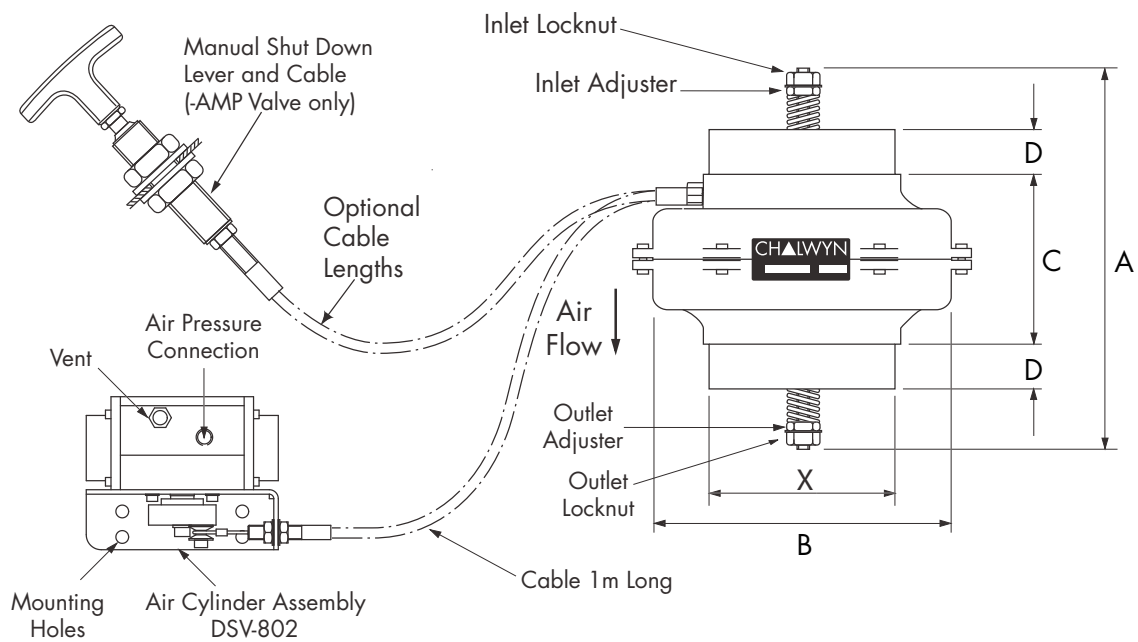

Valve Type	A	B	C	D	WEIGHT (Valve only) Kg
D92-AP and 92-AMP	253	162	136	25	2.1
D102-AP and 102-AMP	253	177	132	25	2.5
D121-AP and 121-AMP	310	210	150	25	3.7
D136-AP and 136-AMP	310	240	160	25	4.8

Outside diameter 'X' is selected to suit the size of the engine air intake hose - see page 3 "SELECTION".

SELECTION

1. If manual shut down is required in addition to air pressure and automatic overspeed shut down select valve types “-AMP.” If manual shut down is not required select valve types “-AP”.
2. Determine the rating of the engine to which the valve is to be fitted. Using the table below identify which valve(s) would be suitable. Finalise the selection by identifying the valve which can also be supplied with end diameters to match the bore of the engine air intake hose at the position the valve is to be fitted. **Note**, end diameters “x” are manufactured to the nearest 1mm. Generally, where more than one valve meets all requirements, select the larger valve size to minimise engine air intake restriction.

Valve selection chart in metric units

Valve Type	Engine power at rated speed kW	Engine Air intake hose bore mm	
		Minimum	Maximum
D92-AP & D92-AMP	80 to 101	76	115
D92S-AP & D92S-AMP	102 to 190	76	115
D102-AP & D102-AMP	100 to 123	89	115
D102S-AP & D102S-AMP	124 to 250	89	115
D121-AP & D121-AMP	130 to 158	101	140
D121S-AP & D121S-AMP	159 to 321	101	140
D136-AP & D136-AMP	150 to 188	126	154
D136S-AP & D136S-AMP	189 to 392	126	154

Valve selection chart in non-metric units

Valve Type	Engine power at rated speed hp	Engine Air intake hose bore inches	
		Minimum	Maximum
D92-AP & D92-AMP	107 to 135	3	4 1/2
D92S-AP & D92S-AMP	136 to 255	3	4 1/2
D102-AP & D102-AMP	134 to 165	3 1/2	4 1/2
D102S-AP & D102S-AMP	166 to 335	3 1/2	4 1/2
D121-AP & D121-AMP	174 to 212	4	5 1/2
D121S-AP & D121S-AMP	213 to 430	4	5 1/2
D136-AP & D136-AMP	201 to 252	5	6 1/16
D136S-AP & D136S-AMP	253 to 525	5	6 1/16

3. In the case of “AMP” valves also select the required length of the manual shut down cable from the table across. Alternative lengths may be available on request.

CABLE PART NO	LENGTH (Metres)
CLD-100	1.0
CLD-150	1.5
CLD-200	2.0
CLD-300	3.0

Notes: * For smaller valve sizes see TPZ valve data sheet CE 237.
* For larger valve sizes see “D200” valve data sheet CE 231.

FITTING

1. These valves are supplied with the shut down air cylinder assembled to the valve with all adjustments completed. Type “-AMP” valves are also supplied with the manual shut down cable and lever fitted. It is recommended that these assemblies are not separated during fitting
 2. The Chalwyn valve is designed for fitting as close to the engine air intake manifold as possible. Where an engine air intake flametrap is also fitted, the Chalwyn valve must always be positioned on the upstream (air cleaner) side of the flametrap. These same requirements are generally applicable to both naturally aspirated and turbocharged engines but in the case of a turbocharged engine the following may be applicable.
 - a) Insufficient space to fit between the turbocharger and engine. In this case the valve may be fitted upstream of the turbocharger.
 - b) The turbocharger air outlet temperature is exceptionally high (200° C plus). In this case fit the valve downstream of the intercooler or upstream of the turbocharger.
- Note: Where the valve is fitted immediately upstream of the turbocharger, ensure that the valve spindle does not project into the turbocharger when the valve closes.
3. Where more than one Chalwyn valve is fitted to an engine as in the case of an engine with multiple intake pipes, a balance pipe arrangement must be installed to connect the various intake pipes together downstream (engine side) of the shut down valves. Typically balance pipe diameters should be about 30% of the diameter of the intake pipes.
 4. When fitting ensure the direction of air flow is in compliance with direction shown on the body. The valve may be installed either horizontally or vertically. Ensure that the mechanical cables are installed without tight bends and are positioned to avoid mechanical damage or damage from hot surfaces.
 5. The flexible cuffs at the inlet and outlet of the valve should be of a re-inforced type, provide adequate support for the valve and prevent excessive vibration. If necessary, additional support brackets mounted from the engine should be considered.
 6. Particular care must be taken to ensure the integrity of the intake pipework between the Chalwyn valve and intake manifold. Ideally metal pipework should be used and any gaps kept as short as possible (taking into account any relative movement) and closed by reinforced hose. The possibility of a hose collapse on closure of the shut down valve should be avoided.
 7. Any engine crankcase breather connections into the intake system between the Chalwyn valve and engine, or any internal crankcase breather arrangement venting directly into the engine intake ports, must be sealed and replaced by an external breather system venting either to atmosphere or to the intake system upstream of the shut down valve. External breather system kits for various engine types are available from Chalwyn.
 8. Securely locate the air cylinder assembly using the four mounting holes provided.
 9. Connect the CLEAN, DRY shut down air supply to the inlet port of the shut down valve cylinder. The air exhaust port should also be piped back to clean, dry air to avoid moisture or dust being drawn back into the air cylinder. **Note:** A shut down air supply pressure of 2.5 bar (36 psi) to 8 bar (116 psi) is required to operate the shut down. See note reference “Adjustment of Air Cylinder - page 6
 10. In the case of -AMP valves fit the ‘T’ handle assembly RTD-100 through a suitable Ø20mm ($\frac{3}{4}$ " diameter) hole in a bulkhead or mounting bracket as follows. Release the handle locknut. Remove the handle, handle locknut and upper locknut and washer. Thread handle body through the bulkhead/ bracket. Refit upper locknut and washer. Adjust lower and upper locknut to position handle and tighten. Refit handle locknut and handle. Tighten locknut.

FITTING cont.

Important Notes

For some of the largest size valves, handle assembly RLD-100 is supplied in place of RTD-100. In this case a suitable bracket will need to be made up to mount the handle assembly.

It takes a significant force to move the valve to the fully closed position using the RLD-100 (or RTD-100) handle when the engine is not running. This is a design feature and adjustment is not necessary. When the engine is running, manual shut down will be achieved satisfactorily using considerably less force to operate the shut down lever.

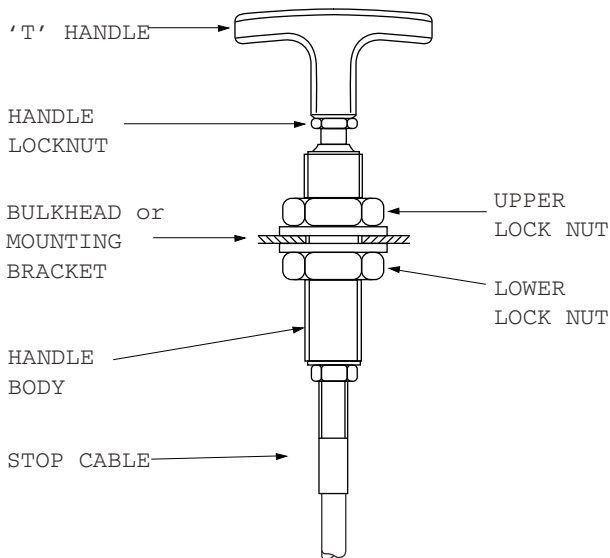

ADJUSTMENT

Once the Chalwyn valve is installed, adjustment of the overspeed trip setting is carried out using the inlet adjuster and locknut (refer to diagram). Basically rotating the inlet adjuster clockwise will increase the engine speed at which automatic shut down occurs.

As supplied, the valve will be adjusted such that shut down will generally occur well below the engine high idle speed. To increase the shut down speed to the required setting proceed as follows:-

Note. Prior to carrying out the following adjustments check that the air pressure shut down control and, where fitted, the manual shut down control, are in the "run" position.

1. Start engine. Slowly accelerate. Note speed at which shut down occurs.
2. Remove hose at **air inlet** to Chalwyn valve to expose the adjuster and locknut (see diagram).
3. Release locknut. Turn adjuster clockwise one turn. Tighten locknut.
4. Refit inlet hose to Chalwyn valve.
5. Start engine. Slowly accelerate. Note speed at which shut down occurs.
6. Repeat the above steps '2' to '5' until the first setting at which the engine does not shut down at high idle speed (i.e. maximum throttle, no load). Then either:
 - a) *Use the results of shut down speed versus adjuster setting as a calibration check to make a*
 - b) *final adjustment to give the required setting (typically 10% to 15% over high idle).*
7. Ensure the adjuster locknut is fully tightened. (Use a thread lock adhesive on the locknut threads).
8. After completing the valve adjustment, check the functioning of the air pressure shut down and, if applicable, the manual shut down, by operating each in turn with the engine running at medium speed. The engine should stop within a few seconds in each case.

Important Notes:

Adjustment of Air Cylinder.

The air pressure shut down arrangement is adjusted such that when operated with the engine not running, it makes the valve close to within about 1mm of the valve seat. This will give satisfactory operation of the valve when the engine is running DO NOT adjust the system such that the air cylinder pulls the valve into contact with the valve seat as this may result in early cable failure..

Insufficient Overspeed Adjustment.

Should there be insufficient adjustment available to set the required overspeed trip point, the outlet locknut should be released and the outlet adjuster rotated anticlockwise by four turns. The outlet locknut should then be treated with a thread lock adhesive and securely tightened. Further adjustment to the inlet adjuster as per above instructions is then continued.

Turbocharged Engines.

When setting up a valve on a turbocharged engine using the preceding method, it may be found that at high power outputs, the engine will shut down at a lower speed than required. If this occurs, further small adjustments in steps of one half turn clockwise should be made until the problem is eliminated.

MAINTENANCE

Routine maintenance should be undertaken as below:-

Daily: Run engine in the mid speed range. Apply the air pressure shut signal and check that the engine stops within a few seconds.

Three Monthly

1. Disconnect intake pipework and release the valve from any support brackets etc. to allow it to be removed.
2. Inspect the valve internally for cleanliness. If necessary, clean in paraffin or white spirit taking normal precautions. Dry the valve thoroughly.
3. Check there is no excessive wear and that the valve moves smoothly over its complete operating stroke. **DO NOT LUBRICATE.**
4. Refit valve. Check valve setting based on the "Adjustment" instructions given herein.

5. Operate the air pressure shut down system whilst the engine is running at medium speed. The engine should stop within a few seconds.
6. Where applicable operate the manual shut down control with the engine running at medium speed. The engine should stop within a few seconds.

Note: If the valve fails to function correctly, or if there is any doubt about the operation of the valve, it should be withdrawn from service until corrective action has been completed.

Important Notes:

The three monthly routine maintenance period requirement is dependent on the operating conditions to which the equipment is exposed and, by experience, may need to be varied.

Any maintenance problems not covered by the routine maintenance schedule should be discussed with your Chalwyn Distributor before any repair work is undertaken



Chalwyn by AMOT

sales@chalwyn.co.uk
www.chalwyn.com

A division of Roper Industries Limited

UK

Western Way
Bury St Edmunds
Suffolk, IP33 3SZ
Tel: +44 (0)1284 715739
Fax: +44 (0)1284 715747

USA

8824 Fallbrook Drive
Houston
TX 77064
Tel: +1 (281) 940 1800
Fax: +1 (713) 559 9419

