



MPX-Series Diesel Engine Shut Down Valves (Manual Reset / Air Pressure and Manual Closure Options)

Selection, Application and Maintenance

Valve Numbers			
MPX-300	MPX-301	MPX-302	MPX-303
MPX-500	MPX-501	MPX-502	MPX-503
MPX-800	MPX-801	MPX-802	MPX-803

Diesel Engine Shutdown Valves - MPX 300 - 803

DESCRIPTION

A range of 3", 5" and 8" bore slim butterfly air intake shut down valves with air pressure actuated shut down combined with manual reset and the optional addition of manual shut down. Suitable for both hazardous and non-hazardous area applications. MPX valves are available in basic flange mounted form or fitted with hose adaptors. Valve body and disc are manufactured in corrosion resistant hard anodised aluminium with PTFE coating. The valve spindle and mechanism is made from stainless steel.

Notes:

Maximum temperature of the engine intake air at the MPX valve not to exceed 150°C. (See also 'Installation' - page 5).

For alternative types of air pressure actuated Chalwyn valves see brochure CE218.

Main Dimensions (mm)

Valve Type	Nominal Bore Diameter	A	B	C1	C2 minimum & maximum
MPX-300 MPX-301 MPX-302 MPX-303	76 (3")	190.0 207.0 190.0 223.0	111.5	37.5	82.5 to 112.5
MPX-500 MPX-501 MPX-502 MPX-503	127 (5")	246.0 263.0 246.0 279.0	167.0	45.5	102.0 to 157.5
MPX-800 MPX-801 MPX-802 MPX-803	203 (8")	346.5 362.0 346.5 377.5	257.0	56.0	136.5 to 185.5

Valve Types MPX-300, MPX-500 and MPX-800

(Air Pressure Shut Down, Manual Reset)

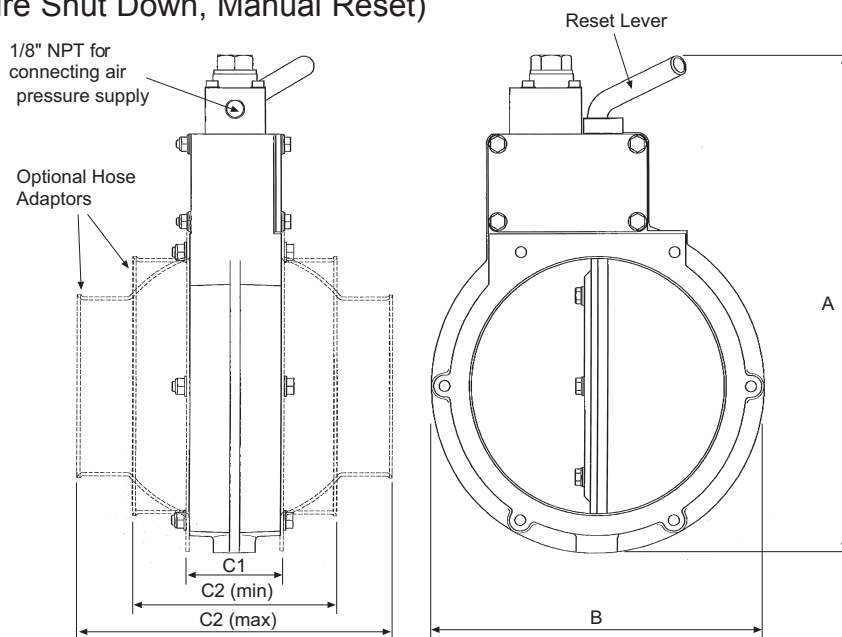

Diesel Engine Shutdown Valves - MPX 300 - 803

Valve Types MPX-301, MPX-501 and MPX-801

(Air Pressure and Integral Stop Button Shut Down, Manual Reset)

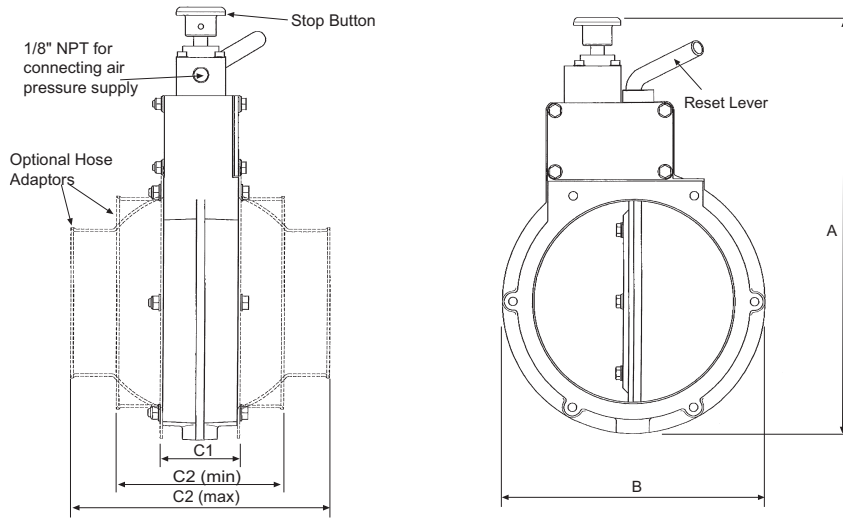

Valve types MPX-302, MPX-502 and MPX-802

(Air Pressure and Remote "Push" Stop Button Shut down, Manual Reset)

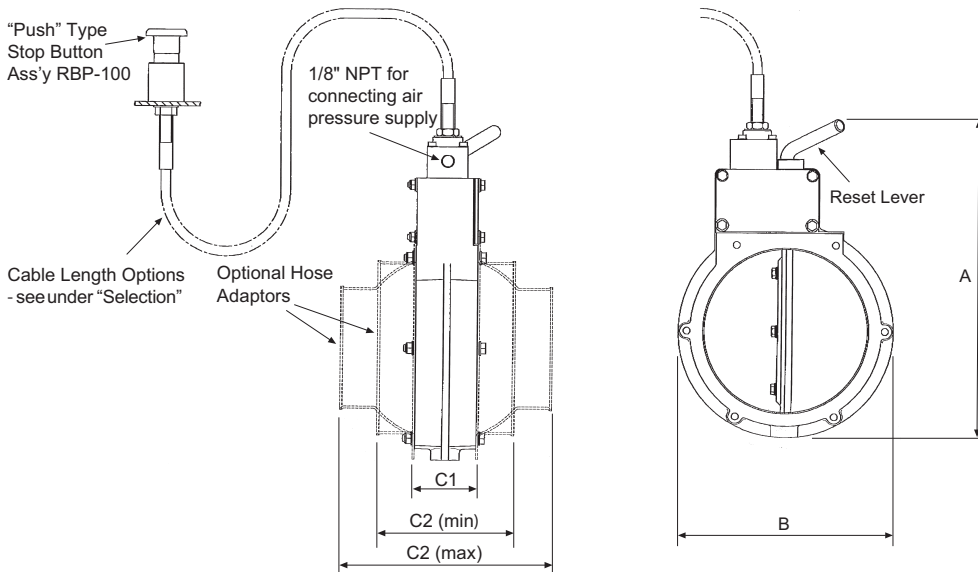

Valve Types MPX-303, MPX-503 and MPX-803

(Air Pressure and Remote "Pull" Shut Down, Manual Reset)

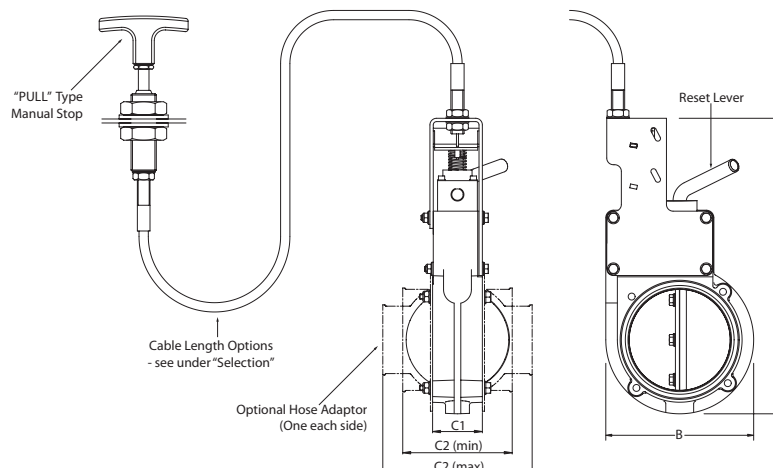

Diesel Engine Shutdown Valves - MPX 300 - 803

SELECTION

Determine the size and position of the MPX valve to be installed. Within the various constraints imposed in the application, the valve should be as generously sized as possible. Check that the valve can be positioned such that the reset lever and, where applicable, the stop button will be easily and safely accessible. For types with a remote manual stop, position the valve and select the cable length to give a reasonably straight cable run between the MPX valve and the proposed stop button position.

Air Pressure

A clean, dry air supply is required. An air pressure of approximately 2 bar is required to close the valve. Maximum air pressure must not exceed 10 bar.

Cable options for use with "PUSH" button RBP-100
To suit valves MPX-302, MPX-502, or MPX-802

Cable part No.	Length (meters)
CLP-100	1.0
CLP-150	1.5
CLP-200	2.0
CLP-300	3.0

Select the required length of the manual shut down cable from the table. Alternative lengths may be available on request. Also order push button assembly RBP-100.

Cable options for use with "PULL" handle RTD-100
To suit valves MPX-303, MPX-503, or MPX-803

Cable part No.	Length (meters)
CLD-100	1.0
CLD-150	1.5
CLD-200	2.0
CLD-300	3.0

Select the required length of the manual shut down cable from the table. Alternative lengths may be available on request. Also order handle RTD-100.

If the valve is to be fitted into a hose as opposed to flange mounted, suitable hose adaptors may be selected from the table below for ordering with the valve.

Hose Adaptor Options

76mm (3") Bore Valves	
Adaptor Part Number	To Suit Hose Bore mm (inches)
HAX-320	38 (1½)
HAX-322	44.5 (1¾)
HAX-301	51 (2)
HAX-303	57 (2¼)
HAX-304	60 (2⅜)
HAX-305	63.5 (2½)
HAX-306	67 (2⅝)
HAX-307	70 (2¾)
HAX-309	76 (3)
HAX-314	89 (3½)
HAX-319	102 (4)

127mm (5") Bore Valves	
Adaptor Part Number	To Suit Hose Bore mm (inches)
HAX-501	89 (3½)
HAX-503	95 (3¾)
HAX-505	102 (4)
HAX-507	108 (4¼)
HAX-509	114 (4½)
HAX-511	121 (4¾)
HAX-513	127 (5)
HAX-518	140 (5½)
HAX-523	152 (6)

203mm (8") Bore Valves	
Adaptor Part Number	To Suit Hose Bore mm (inches)
HAX-807	178 (7)
HAX-808	203 (8)

Diesel Engine Shutdown Valves - MPX 300 - 803

INSTALLATION

1. In the case of a naturally aspirated engine the Chalwyn MPX shut down valve should generally be fitted as close to the engine air intake manifold as possible. If an air intake flame trap is also fitted, the MPX valve must be installed upstream (air cleaner side) of the flame trap.
2. To avoid excessively high intake air temperatures at the MPX valve when fitted to a turbo-charged engine, it may be necessary to fit the valve either upstream of the turbocharger or downstream of the intercooler (where fitted). Again, if an air intake flametrap is also installed, the valve must be fitted upstream of the flametrap.
3. Where more than one MPX valve is fitted to an engine, as in the case of an engine with multiple intake pipes, a common pneumatic supply to the valves should be used to ensure that all valves close simultaneously.
4. The MPX valve may be installed either horizontally or vertically. Air flow may be in either direction through the valve. Ensure easy and safe access to the valve reset lever and, where applicable, manual stop control. If the valve is fitted with a cable operated manual stop ensure a reasonably straight run for the cable.
5. If hose adaptors are used, the mating hose should be of a reinforced type, provide adequate support for the valve and prevent excessive vibration. If necessary, additional support brackets mounted from the engine should be considered.
6. Particular care must be taken to ensure the integrity of the intake pipework between the Chalwyn valve and intake manifold. Ideally metal pipework should be used and any gaps kept as short as possible, (taking into account any relative movement) and closed by reinforced hose. The possibility of a hose collapse on closure of the shut down valve must be avoided.
7. Any engine crankcase breather connections into the intake system between the MPX valve and engine, or any internal crankcase breather arrangement venting directly into the engine intake ports must be sealed and replaced by an external breather system venting either to atmosphere or to the intake system upstream of the shut down valve. External breather system

kits for various engine types are available from Chalwyn.

8. For valves with the "Push" button cable operated manual shut down, drill a $\text{\O}10\text{mm}$ ($3/8"$ clearance) hole through the bulkhead (or bracket) to which the stop button is to be mounted. Pass cable end through hole. With the MPX valve in the **latched open position** check that, with the cable inner pressed hard back into the

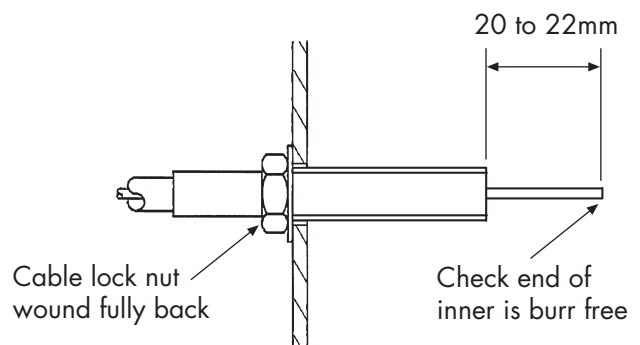

cable outer, between 20mm and 22mm of the inner shows

With the MPX valve still **latched open**, use a 2mm A/F hexagon key to release the cable grip screw in assembly RBP-100 to enable the assembly to be fully screwed onto the cable outer.

Then tighten the cable locknut onto the back face of the bulkhead. Finally, fully tighten the cable grip screw (see diagram below).

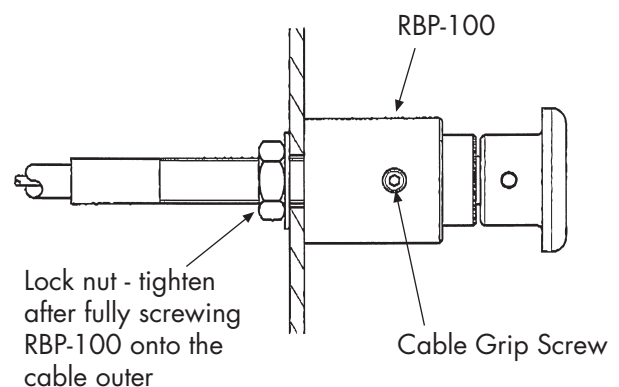

Diesel Engine Shutdown Valves - MPX 300 - 803

9. For valves with the “pull” handle cable operated manual shut down, fit the ‘T’ handle assembly RTD-100 through a suitable Ø20mm (3/4”dia) hole in a bulkhead or mounting bracket as follows. Release the handle locknut. Remove the handle, handle locknut and upper locknut and washer. Thread handle body through the bulkhead/bracket. Refit upper locknut and washer. Adjust lower and upper locknuts to position handle and tighten. Refit handle locknut and handle. Tighten locknut.

10. Connect shut down air supply using the 1/4NPT tapping on valve. Means must be provided to release any trapped air pressure at the MPX valve connection when the air pressure shut down signal is not being applied.

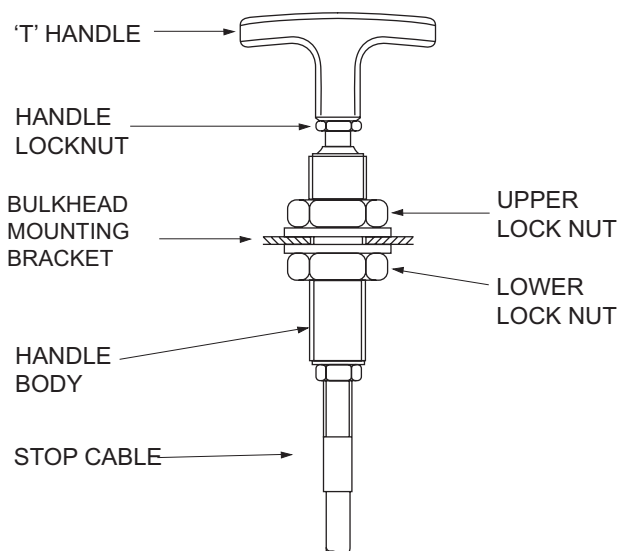

11. Prior to putting the engine into service the checks listed under “Monthly” maintenance should first be completed (see page 7).

Diesel Engine Shutdown Valves - MPX 300 - 803

OPERATION

Prior to starting the diesel engine the MPX valve must be latched in the open position by rotating the reset lever clockwise as far as possible. Once latched, the reset lever and valve will remain in the latched open position until released by application of air pressure or by operating the stop button.

After an emergency shut down by air pressure or by operating the stop button, the MPX valve must always be reset before re-starting the engine.

After a normal (diesel fuel only) shut down, the MPX valve will not require reset.

MAINTENANCE

MONTHLY:

Check that all intake system fasteners and any associated support bracket fasteners are securely tightened.

Check that any intake system hoses between the MPX valve and engine are free from damage and suitable for further service.

Run engine, preferably at or just above low idle speed. Apply shut down air pressure signal to valve. Check that the valve reset lever immediately rotates to the valve closed position and the engine stops within a few seconds.

Run engine, preferably at or just above low idle speed. Operate the manual shut down control. Check that the valve reset lever immediately rotates to the valve closed position and the engine stops within a few seconds.

Notes:

The engine must not be put back into service until any problems identified by the above checks are rectified.

Americas

AMOT - USA
Tel: +1 281 940 1800
Fax: +1 713 559 9419
info@amotusa.com

Roda Deaco by AMOT - Canada
Tel: +1 780 465 4429
Fax: +1 780 469 6275
info@rodadeaco.com

Asia Pacific

AMOT - China
Tel: +86 (0)21 6279 7700
Fax: +86 (0)21 5237 8560
shanghai@amot.com

AMOT - Singapore
Tel: +65 6408 6265
Fax: +65 6408 6266
singapore@amot.com

Europe, Middle East and Africa

AMOT - UK
Tel: +44 (0)1284 715739
Fax: +44 (0)1284 715747
info@amot.com

AMOT - Germany
Tel: +49 (0)40 8537 1298
Fax: +49 (0)40 8537 1331
germany@amot.com

AMOT - Russia
Tel: +7 495 617 12 96
Fax: +7 495 913 97 65
russia@amot.com

