

Diesel Engine Shutdown Valve

Models PVX-300, 301
PVX-500, 501
PVX-800, 801
(Pneumatically Actuated)

Typical Applications

PVX-300, PVX-500, PVX-800

- Failsafe application to meet EU ATEX 94/9/EC defined hazardous areas
- Zone 1 and 2 applications to EN 1834 engine safety standards
- US offshore engines to Class 1 Div 2 and Div 1 safety standards
- International offshore platform engine installations

PVX-301, PVX 501, PVX 801

- Petrochemical and LNG refineries
- All international areas where non-failsafe is permitted
- US offshore BOEMRE 2011 Safety Standards
- Zone 2 fire pump engine offshore applications
- Vehicles with air brakes
- Fuel tankers
- Emergency vehicles
- Vacuum trucks

Key benefits

- Simple direct air pressure operation
- Build options to either open or close on the application of air pressure
- Automatic reset on loss of air pressure
- Valve status indicator
- Combination of body sizes and hose adaptors to suit air intake diameters from 38 mm (1 1/2 inches) to 203 mm (8 inches)



CHALWYN
by AMOT

www.chalwyn.com

Diesel Engine Shutdown Valve - PVX

Diesel Engine Shutdown Valve - PVX

Description

Pneumatically operated diesel engine air intake closure valves based on the standard Chalwyn slimfit 3", 5" and 8" bore butterfly valves with variants for both hazardous and non-hazardous areas.

Available in basic flange mounted form or supplied fitted with hose adaptors or an integral

flame trap housing (3" valves only).

Body and disc manufactured in corrosion resistant hard anodised aluminium with PTFE coating. Suitable for salt air offshore environments.

Typical PVX Valve Arrangement

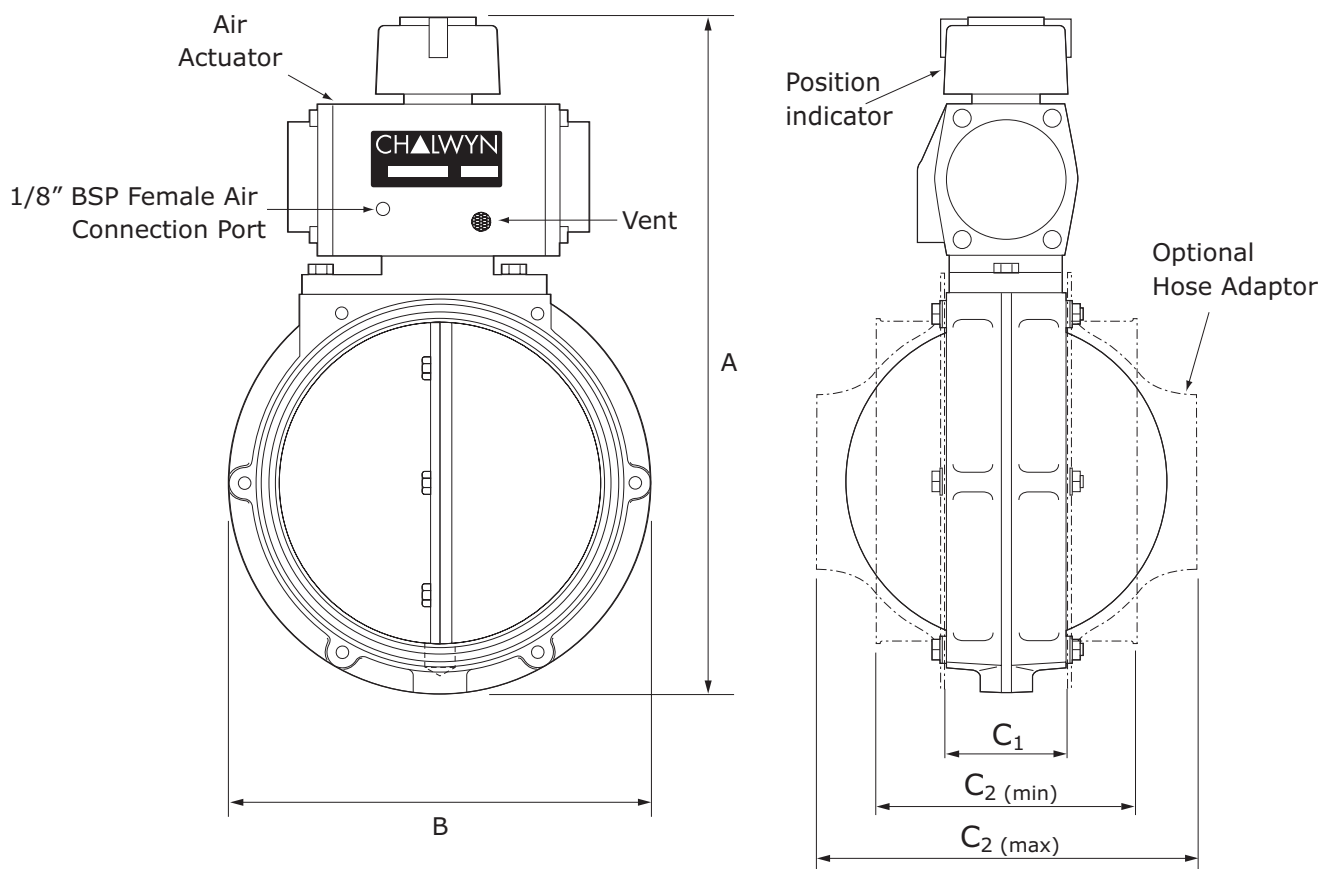

Main Dimensions (mm)

Valve Type	Nominal Bore Diameter	A mm	B mm	C ₁ mm	C ₂ min & max *
PVX-300	76 (3")	208.0	111.5	37.5	82.5 to 112.5
PVX-301					
PVX-500	127 (5")	257.0	167.0	45.5	102.0 to 157.5
PVX-501					
PVX-800	203 (8")	354.5	257.0	56.0	136.5 to 185.5
PVX-801					

* If accurate C₂ measurement is required please contact Chalwyn.

Diesel Engine Shutdown Valve - PVX

Selection

Determine the size and position of the PVX valve to be installed. Within the various constraints imposed in the application the valve should be as generously sized as possible. A pneumatic supply must be available to operate this valve type.

PVX-300, PVX-500 and PVX-800 valves open on the application of air pressure. The 'fail safe' mode of operation of the PVX-300, PVX-500 and PVX-800 models makes them suitable for use in zone 1 hazardous areas.

PVX-301, PVX-501 and PVX-801 close on the application of air pressure. This type of valve and

Chalwyn control system is recommended for larger vehicles that have air brakes (see page 7).

The actuators fitted to these valves are suitable for an operating temperature range between -20°C (-4°F) and 120°C (248°F) and a maximum applied pressure of 8 bar (120 psi).

Ideally if hose adaptors or an integral intake flame trap housing is to be used, these should be identified and ordered from Chalwyn at the same time as the basic PVX valve.

Hose Adaptor Options

76mm (3") PVX-30* Bore Valves	
Adaptor Part Number	To Suit Hose Bore mm (inches)
HAX-320	38 (1 1/2)
HAX-322	44 (1 3/4)
HAX-301	51 (2)
HAX-303	57 (2 1/4)
HAX-304	60 (2 3/8)
HAX-305	63.5 (2 1/2)
HAX-306	67 (2 5/8)
HAX-307	70 (2 3/4)
HAX-309	76 (3)
HAX-312	82 (3 1/4)
HAX-314	89 (3 1/2)
HAX-319	102 (4)

127mm (5") PVX-50* Bore Valves	
Adaptor Part Number	To Suit Hose Bore mm (inches)
HAX-501	89 (3 1/2)
HAX-503	95 (3 3/4)
HAX-505	102 (4)
HAX-507	108 (4 1/4)
HAX-509	114 (4 1/2)
HAX-511	121 (4 3/4)
HAX-513	127 (5)
HAX-518	140 (5 1/2)
HAX-523	152 (6)

203mm (8") PVX-80* Bore Valves	
Adaptor Part Number	To Suit Hose Bore mm (inches)
HAX-807	178 (7)
HAX-808	203 (8)

Diesel Engine Shutdown Valve - PVX

Installation

1. In the case of a naturally aspirated engine the Chalwyn PVX shut down valve should generally be fitted as close to the engine air intake manifold as possible. If an air intake flame trap is also fitted, the PVX valve must be installed upstream (air cleaner side) of the flame trap.
2. To avoid excessively high intake air temperatures at the PVX valve when fitted to a turbocharged engine, it may be necessary to fit the PVX valve either upstream of the turbocharger or downstream of the intercooler (if fitted). Again, if an air intake flametrap is also fitted, the valve must be installed upstream of the flametrap.
3. Where more than one PVX valve is fitted to an engine, as in the case of an engine with multiple intake pipes, a common pneumatic supply to the valves should be used to ensure that all valves close simultaneously. A balance pipe arrangement should also be incorporated to connect the separate intake pipes together downstream (engine side) of the shut down valves. Typically balance pipe diameters should be about 30% of the diameter of the intake pipes.
4. The PVX valve may be installed at any convenient angle.
5. If hose adaptors are used, the mating hose should be of a reinforced or strong silicone type, provide adequate support for the valve and prevent excessive vibration. If necessary, additional support brackets mounted from the engine should be considered.
6. Particular care must be taken to ensure the integrity of the intake pipework between the Chalwyn valve and intake manifold. Ideally metal pipework should be used and any gaps kept as short as possible, (taking into account any relative movement) and closed by reinforced hose. The possibility of a hose collapse on closure of the shut down valve must be avoided.
7. Any engine crankcase breather connections into the intake system between the PVX valve and engine, or any internal crankcase breather arrangement venting directly into the engine intake ports must be sealed and replaced by an external breather system venting either to atmosphere or to the intake system upstream of the shut down valve. External breather system kits for various engine types are available from Chalwyn.
8. Connect the intake port of the actuator to the air supply using suitable pipe and 1/8" BSP connector (male, parallel).
9. A fitting kit of several connectors with suitable BSP threads is available from Chalwyn as part SKA-100. This includes flexible hose.
10. For further installation schematics and details of electric systems to operate PVX-301 or PVX-501 on vehicles, please see 'System Selection Guide' at www.dieselsafety.com/technical downloads. (Some detail of this is shown on page 7).

Notes

Maximum temperature of the engine intake air at the PVX valve not to exceed 150°C.

Alternative types of air actuated valves are available from Chalwyn - see brochures CE231, CE236 and CE237.

If automatic diesel fuel shut down is required in combination with air intake shut down a Chalwyn FSX-200 fuel shut down valve should also be specified (brochure CE226). Also order chosen PVX valve with 'Y' suffix and an FKX-300 fitting kit for easiest connections to the FSX-200.

Diesel Engine Shutdown Valve - PVX

Operation

PVX-300, PVX-500 and PVX-800

Prior to engine start, air pressure must be applied to these failsafe PVX valves to open to the engine run position. (Note, the external yellow indicator on the valve shows the position of the valve disc). Air pressure must be maintained between 4 and 8 bar to hold the intake valve fully open whilst the engine runs.

To carry out an emergency engine stop by closing the air intake valve, close down the air supply and vent the supply line. The valve will fully close once the air supply pressure at the valve falls below 2 bar.

NOTE: The pneumatic supply to the valve must be clean and dry.

PVX-301, PVX-501 and PVX-801

With no air pressure applied to these PVX valves they will be naturally sprung fully open and the engine may be run.

To carry out an emergency stop apply an air pressure of 4 to 8 bar to close the intake shut down valve.

The supply pressure must be vented before attempting to re-start the engine. This venting will happen automatically and at a controlled slow speed when kit SKA-100 and 24 Volt Solenoid SVA-200 are installed and the outlet vent device is adjusted correctly. The PVX valve will then return to open position allowing the engine to run.

Maintenance

Weekly:

Exercise the valve by applying and venting the control air supply pressure. Check by observing the external position indicator that the valve is freely moving between the open and closed positions.

For vehicle installations this can be done by holding the manual toggle electric switch as shown in the 'System Selection Guide' schematic on page 11.

The PVX-301/501 will reset to open automatically when the switch is released.

Monthly:

Check that the fasteners locating the PVX valve and any associated intake system or support bracket fasteners are securely tightened.

Check that any flexible hoses in the engine intake system between the PVX valve and engine are free from damage and suitable for further service.

Check that the air supply pipe to the PVX valve is properly supported, free from damage and the pipe fittings are tight.

Run engine, preferably at low idle. Vent (or supply as appropriate) the control air pressure to the PVX valve and check that the engine stops within a few seconds. If not, check the engine air intake system for leaks. Should this not solve the problem remove the intake valve and return to Chalwyn for further investigation.

Diesel Engine Shutdown Valve - PVX

Control System Information

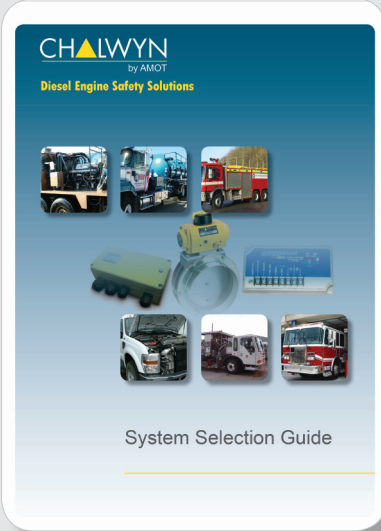

Chalwyn has a broad array of fully automatic shutoff systems and manual shutoff systems. Common operating methods include electric, pneumatic, electric/pneumatic, mechanical, or combinations of these mechanisms. The Chalwyn System Selection

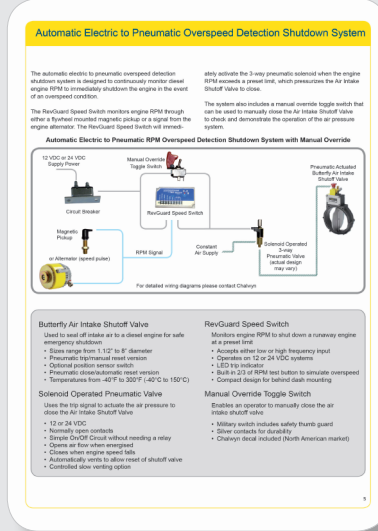

Guide provides an overview of the most common types of systems used in applications today. The overview includes a description of the solution, a diagram of the components and includes the functional highlights of the components used in each solution. These

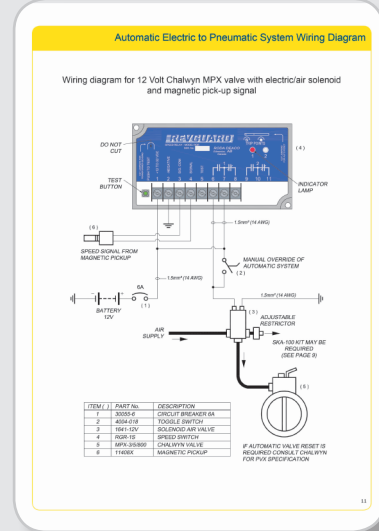

overviews will provide the information required to help you determine the best type of solution for your application.

Download the brochure at www.dieselsafety.com/technicaldownloads

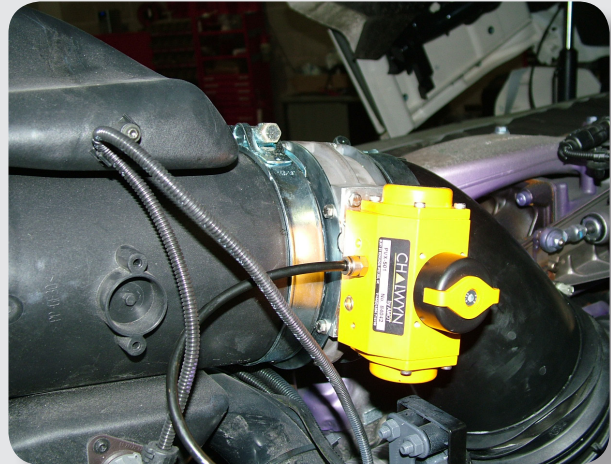

For further details of application of Chalwyn PVX*01 valves for vehicles requiring automatic shutdown of overspeed, please contact Chalwyn or your local distributor (www.dieselsafety.com/distributor).

Americas

AMOT - USA
Tel: +1 281 940 1800
Fax: +1 713 559 9419
info@amotusa.com

Roda Deaco by AMOT - Canada
Tel: +1 780 465 4429
Fax: +1 780 469 6275
info@rodadeaco.com

Asia Pacific

AMOT - China
Tel: +86 (0)21 6279 7700
Fax: +86 (0)21 5237 8560
shanghai@amot.com

AMOT Singapore
Tel: +65 6408 6265
Fax: +65 6408 6266
singapore@amot.com

Europe, Middle East and Africa

AMOT - UK
Tel: +44 (0)1284 715739
Fax: +44 (0)1284 715747
info@amot.com

AMOT - Germany
Tel: +49 (0)40 8537 1298
Fax: +49 (0)40 8537 1331
germany@amot.com



Chalwyn's Quality Management System is approved by LRQA.

www.chalwyn.com

CHALWYN
by AMOT